

DT 2142 HEXAGON ALLEN KEY WITH 2GT-HANDLE

for in-hex screws

- > With hanging hole
- > With 2 hexagons, same size each end
- > GEDORE vanadium steel 61CrSiV5, chromated

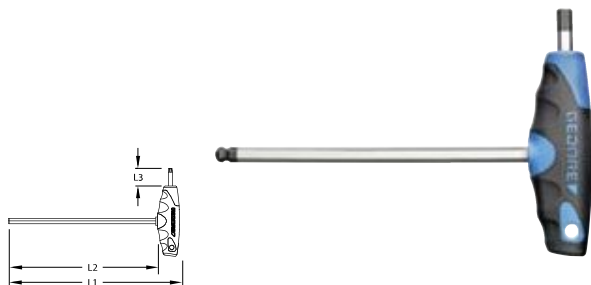

mm	L ₁	L ₂	L ₃	mm	Code	No.
2	152	125	15	0.091	2488914	DT 2142 2
2,5	152	125	15	0.071	2498596	DT 2142 2,5
3	152	125	15	0.040	2498618	DT 2142 3
4	152	125	15	0.080	2498626	DT 2142 4
5	177	150	20	0.100	2502631	DT 2142 5
6	188	150	20	0.120	2502658	DT 2142 6
7	213	175	25	0.251	2505487	DT 2142 7
8	213	175	25	0.180	2507447	DT 2142 8
10	238	200	25	0.280	2507471	DT 2142 10

1500 CT2-DT 2142



>110

2142 TX WRENCH KEY WITH 2GT-HANDLE

for recessed TORX® screws

- > With hanging hole
- > Chrome-vanadium steel, blade chrome-plated, tip gun-metal finish
- > TORX® = reg. trademark of Acument Intellectual Properties, LLC. USA

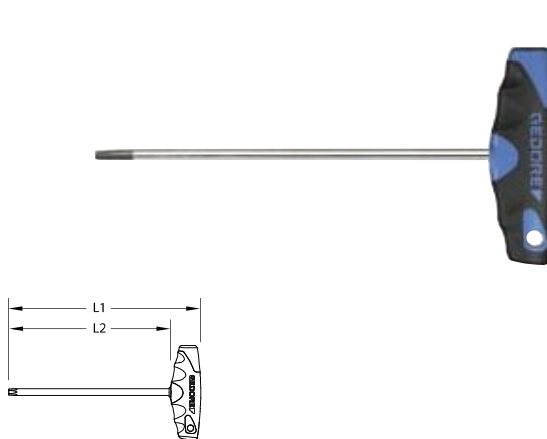

mm	M	mm	L ₁	L ₂	mm	Code	No.
T5	M1,8	1,42	152	125	0.081	2509393	2142 TX T5
T6	M2	1,70	152	125	0.081	2511622	2142 TX T6
T7	M2,5	1,99	152	125	0.081	2511657	2142 TX T7
T8	M2,5	2,31	152	125	0.051	2513072	2142 TX T8
T9	M3	2,50	152	125	0.071	2513102	2142 TX T9
T10	M3 - M3,5	2,74	152	125	0.061	2513749	2142 TX T10
T15	M3,5 - M4	3,27	152	125	0.091	2516934	2142 TX T15
T20	M4 - M5	3,86	152	125	0.081	2519062	2142 TX T20
T25	M4,5 - M5	4,43	177	150	0.091	2519186	2142 TX T25
T27	M4,5 - M6	4,99	177	150	0.100	2521571	2142 TX T27
T30	M6 - M7	5,52	188	150	0.100	2521598	2142 TX T30
T40	M7 - M8	6,65	213	175	0.140	2521601	2142 TX T40
T45	M8 - M10	7,82	213	175	0.160	2521636	2142 TX T45
T50	M10	8,83	238	200	0.180	2521644	2142 TX T50

DT 2143 KTX CRANKED SOCKET KEY WITH 2GT-HANDLE

for recessed TORX® screws

- > Working angle approx. 25°
- > With hanging hole
- > Chrome-vanadium steel, blades chrome-plated, tip phosphated
- > TORX® = reg. trademark of Acument Intellectual Properties, LLC. USA

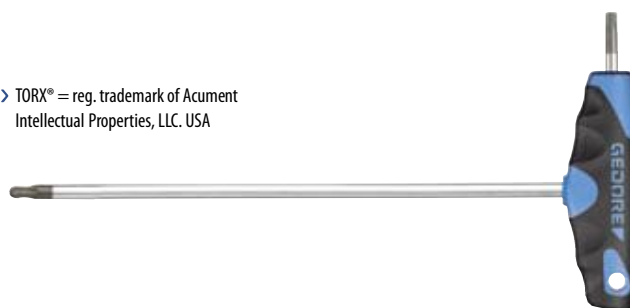
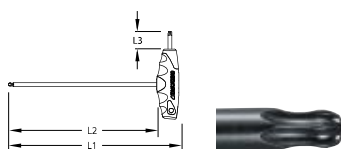

mm	M	mm	L ₁	L ₂	L ₃	mm	Code	No.
T10	M3 - M3,5	2,74	152	125	15	0.091	2647486	DT 2143 KTX T10
T15	M3,5 - M4	3,27	152	125	15	0.081	2647494	DT 2143 KTX T15
T20	M4 - M5	3,86	152	125	15	0.071	2647508	DT 2143 KTX T20
T25	M4,5 - M5	4,43	177	150	20	0.121	2647516	DT 2143 KTX T25
T27	M4,5 - M6	4,99	177	150	20	0.120	2647524	DT 2143 KTX T27
T30	M6 - M7	5,52	188	150	25	0.140	2647532	DT 2143 KTX T30
T40	M7 - M8	6,65	213	175	25	0.180	2647540	DT 2143 KTX T40