

Enerpac hydraulic pumps are available in over 1000 different configurations. Whatever your high-pressure pump needs are... speed, control, intermittent or heavy duty cycle you will find an Enerpac pump suited to the application.

Featuring Hand, Battery, Electric, Air and Gasoline powered models, with multiple reservoir and valve configurations, Enerpac offers the most comprehensive pump line available.



Pump Selection

For help in selecting the correct pump for your application, please view our 'Yellow Pages'.

If you require further assistance, contact the Enerpac office located near you.

Page: 266





















Torque Wrench Pumps

System matched air and electric pumps provide control to operate Enerpac Torque Wrenches.

Page: 212



Pumps and Directional Valves Section Overview

Power Source	Pump Types	Maximum Reservoir Capacity (litres)	Max. Flow at Rated Pressure (l/min)	Max. Power Consumption	Series		Page
Manual	Lightweight Hand Pumps Exclusively from Enerpac	2,5	2,50 (cm ³ /stroke)	–	P		72 ▶
	ULTIMA Steel Hand Pumps	7,4	4,75	–	P		74 ▶
	Low Pressure Hand Pumps	3,3	9,50	–	P		76 ▶
	Multifluid Hand Pumps Pumping Fluids up to 1000 bar	–	20,6 (cm ³ /stroke)	–	MP		78 ▶
	Foot Pump For Hands Free Operation	0,5	2,47 (cm ³ /stroke)	–	P		79 ▶
	Ultra-High Pressure Hand Pumps Pressure up to 2800 bar	1,0	2,49 (cm ³ /stroke)	–	P 11		80 ▶
Electric	Battery Powered Hydraulic Pumps Cordless Hydraulic Power	2,0	0,25	0,37 (kW)	XC		82 ▶
	Economy Series Compact and Portable	3,8	0,32	0,37 (kW)	PU		84 ▶
	Submerged Series Powerful and Low-Noise	5,5	0,27	0,37 (kW)	PE		86 ▶
	Z-Class Pumps, Portable	40	1,0	1,25 (kW)	ZU		92 ▶
	Z-Class Pumps Powerful and Heavy-Duty	40	2,73	5,60 (kW)	ZE		98 ▶
Air	Air Hydraulic Pumps Single and Twin-Air Motor	1,3	0,13	255 (l/min)	PA		104 ▶
		8,0	0,15	510 (l/min)	PAM		105 ▶
	Turbo II Air Hydraulic Pumps Compact Air Over Hydraulic	5,0	0,16	340 (l/min)	PAT		106 ▶
	Air Hydraulic Pumps For Productivity and Ergonomics	2,0	0,25	991 (l/min)	XA		108 ▶
	Z-Class Air Hydraulic Pumps Modular Air Pumps	40,0	1,31	2840 (l/min)	ZA		110 ▶
Gasoline	Z-Class Gasoline Hydraulic Pumps Gas Powered High Flow Pumps	40,0	1,64	4,8 (kW)	ZG5		112 ▶
	Z-Class Gasoline Hydraulic Pumps Gas Powered High Flow Pumps	40,0	3,30	9,7 (kW)	ZG6		112 ▶
Directional Control Valves					VM, VC VE		114 ▶

P-Series, Lightweight Hand Pumps

▼ Shown from top to bottom: P-802, P-842, P-202, P-142



- Lightweight and compact design
- Durable glass-filled nylon reservoir and nylon encapsulated aluminium pump base for maximum corrosion resistance
- Two-speed operation reduces handle strokes by as much as 78% over single speed pumps
- Lower handle effort to minimize operator fatigue
- Integral 4-way valve on P-842 for operation of double-acting cylinders
- Handle lock and lightweight construction for easy carrying
- Large oil capacities to power a wide range of cylinders or tools
- Non-conductive fiberglass handle for improved operator safety
- Internal pressure relief valve for overload protection.

▼ Cylinder-pump set SCR-254H used to support the construction while monitoring pressure and load with the gauge.



Exclusively from Enerpac



Cylinder Matching Chart

For help in selecting the correct hand pump for your application, please refer to the Cylinder Matching Chart located in the 'Yellow Pages'.

Page: 266



Speed Chart

To determine how a specific pump will operate your cylinder, see the Pump-Cylinder Speed Chart in the 'Yellow Pages'.

Page: 273



Tank Kits:

When a return-to-tank port is required, the Tank Kits provide a 7/16"-20 UN port at the rear of the reservoir.

PC-20	Fits P-141, P-142
PC-25	Fits P-202, P-391, P-392



Power Box

Portable tool box with P-392 hand pump, gauge adaptor assembly, hose and RC-, RCS, RSM- or WR-Series cylinder.

Page: 61

Pump Type	Usable Oil Capacity (cm ³)	Model Number	Pressure Rating ²⁾ (bar)		Oil Displacement per Stroke (cm ³)		Max. Handle Effort (kg)
			1 st stage	2 nd stage	1 st stage	2 nd stage	
Single-Speed	327	P-141	-	700	-	0,90	32,7
	901	P-391	-	700	-	2,47	38,6
Two-Speed	327	P-142 ¹⁾	13	700	3,62	0,90	35,4
	901	P-202	13	700	3,62	0,90	28,6
	901	P-392 ¹⁾	13	700	11,26	2,47	42,2
	2540	P-802	27	700	39,33	2,47	43,1
	2540	P-842 ³⁾	27	700	39,33	2,47	43,1

¹⁾ Available as set, see note on next page. P-392 also available in Power Box Set (page 61).

²⁾ Contact Enerpac for applications where operating pressure is less than 10% of pressure rating.

³⁾ P-842 for use with double-acting cylinders

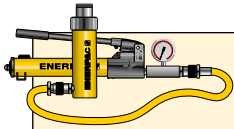

Pump-Cylinder Sets

All pumps marked with an * are available as sets (pump, cylinder, gauge, couplers and hose) for your ordering convenience.

Page: 58

P Series



Reservoir Capacity:

327 - 2540 cm³

Flow at Rated Pressure:

0,90 - 2,47 cm³/stroke

Operating Pressure:

700 bar

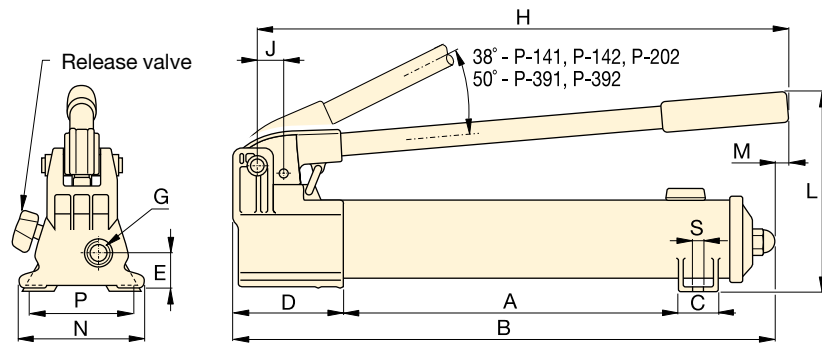

P-141, P-142, P-202, P-391, P-392

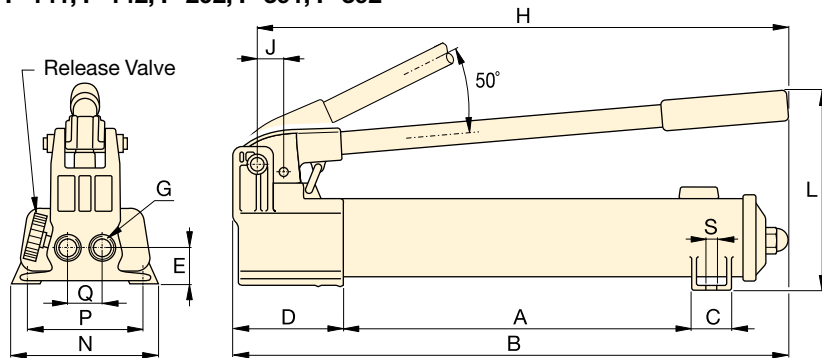

P-802

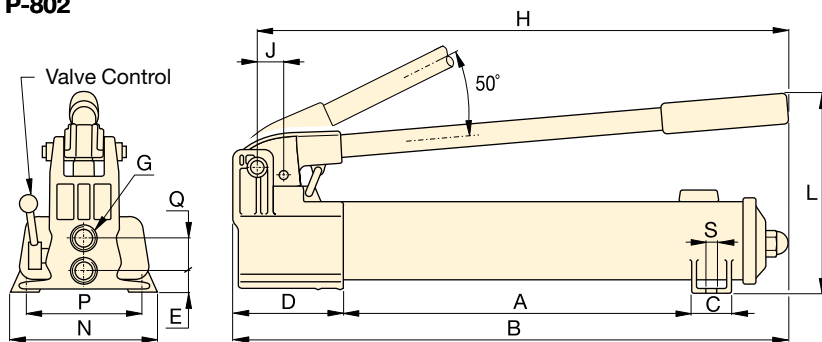

P-842



Hoses

Enerpac offers a complete line of high quality hydraulic hoses. To ensure the integrity of your system, specify only genuine Enerpac hydraulic hoses.

Page: 122



GA45GC Gauge Adaptor

Protect yourself from system overloading by simply ordering one part number for a pre-assembled gauge, adaptor block and coupler.

Page: 134



Foot Pump P-392FP

For handsfree operation the lightweight and robust P-392FP Foot Pump is the perfect choice.

Page: 79

Piston Stroke	Dimensions (mm)															Model Number
	(mm)	A	B	C	D	E	G	H	J	L	M	N	P	Q	S	
12,7	185	336	28	85	28	1/4"-18 NPTF	319	19	143	-	95	80	-	7	2,4	P-141
25,4	344	533	36	99	33	3/8"-18 NPTF	522	30	177	16	120	-	-	-	4,1	P-391
12,7	185	336	28	85	28	1/4"-18 NPTF	319	19	143	-	95	80	-	7	2,4	P-142 ¹⁾
12,7	344	509	36	85	28	1/4"-18 NPTF	400	19	144	16	95	-	-	-	3,4	P-202
25,4	344	533	36	99	33	3/8"-18 NPTF	522	30	177	16	120	-	-	-	4,1	P-392 ¹⁾
25,4	337	552	45	133	35	3/8"-18 NPTF	527	30	228	-	181	153	35	10	8,2	P-802
25,4	337	552	45	133	20	3/8"-18 NPTF	527	30	228	-	181	153	36	10	10,0	P-842 ³⁾

▼ Shown from left to right: P-77, P-80, P-84, P-801, P-39



- Reduced handle effort and ergonomic grip for less operator fatigue
- Two-speed operation for fast and easy operation (except P-39)
- Vent free reservoir eliminates spills
- Quick grip handle allows for easy transport
- Integral reservoir over-pressurization protection
- All steel construction, chrome plated plunger and wiper system for durable, long lasting performance
- 4-way valving on the P-84 and P-464 for operation of double-acting cylinders.

▼ In the absence of a power supply, the P-80 Hand Pump offers a powerful solution.



The Solution for Tough Jobs



Two Speed Pumps

Recommended for applications where cylinder plunger must advance rapidly to load contact, and applications where greater oil capacities are required, such as multiple cylinder hook-ups.



Foot Pump Conversion Kits

Convert your P-39, P-77, P-80 or P-801 to foot power with the **PC-11** Kit. Includes instructions for easy conversion.



GA45GC Gauge Adaptor

Protect yourself from system overloading by simply ordering one part number for a pre-assembled gauge, adaptor block and coupler.

Page: 134



4-Way Control Valve

P-84 and **P-464** feature a manual 4-way control valve, designed for use with one double-acting or two single-acting cylinders. For system set-up information:

Page: 268

Pump Type	Usable Oil Capacity (cm ³)	Model Number	Pressure Rating ²⁾ (bar)		Oil Displacement per Stroke (cm ³)		Max. Handle Effort (kg)
			1 st stage	2 nd stage	1 st stage	2 nd stage	
Single	672	P-39	-	700	-	2,46	39
Two-Speed	672	P-77	34	700	16,39	2,46	40
	2200	P-80 ¹⁾	34	700	16,39	2,46	35
	4100	P-801	34	700	16,39	2,46	35
	2200	P-84 ³⁾	34	700	16,39	2,46	35
	7423	P-462	14	700	126,20	4,75	49
	7423	P-464 ³⁾	14	700	126,20	4,75	49

¹⁾ Available as a set, see note on next page.

²⁾ Contact Enerpac for applications where operating pressure is less than 10% of pressure rating.

³⁾ P84, P-464 is for use with double-acting cylinders.

ULTIMA Steel Hand Pumps



Speed Chart

To determine how a specific pump will operate your cylinder, see the Pump-Cylinder Speed Chart in the 'Yellow Pages'.

Page: 273

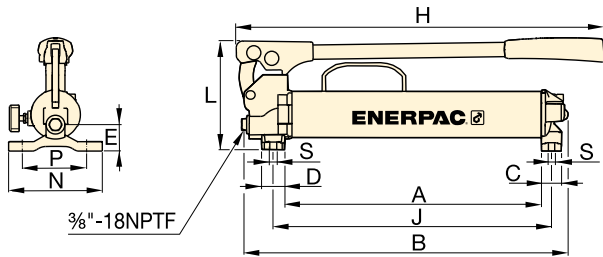

P-39, P-77

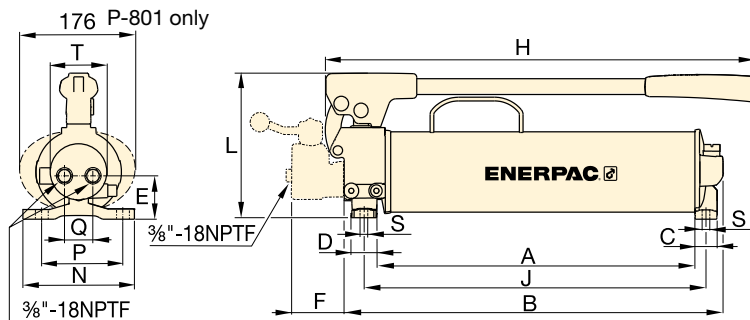

P-80, P-801, P-84

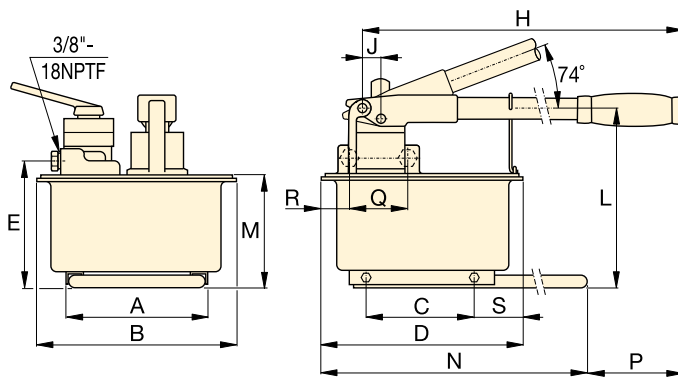

P-462, P-464

P Series



Reservoir Capacity:
672 - 7423 cm³

Flow at Rated Pressure:
2,46 - 4,75 cm³/stroke

Maximum Operating Pressure:
700 bar



Extra Capacity Hand Pumps

P-462 and P-464 feature extra large reservoirs and high first-stage flow rate.

These pumps are ideally suited for powering high-capacity cylinders.

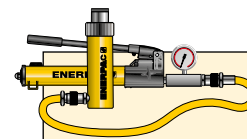

Pump-Cylinder Sets

The P-80 is also available as set (pump, cylinder, gauge, couplers and hose) for your ordering convenience.

Page: 58



Cylinder Matching Chart

For help in selecting the correct hand pump for your application, please refer to the Cylinder Matching Chart located in the 'Yellow Pages'.

Page: 266

Piston Stroke	Dimensions (mm)																Model Number	
	(mm)	A	B	C	D	E	F	H	J	L	M	N	P	Q	R	S		T
25,4	383	480	30	35	37	-	550	416	163	-	140	111	-	-	8,4	-	6,2	P-39
25,4	391	487	30	35	47	-	550	424	163	-	140	111	-	-	8,4	-	7,1	P-77
25,4	428	511	30	35	55	-	579	460	195	-	150	121	42	-	8,4	74	10,7	P-80 ¹⁾
25,4	428	511	30	35	55	-	579	460	195	-	150	121	42	-	8,4	74	14,1	P-801
25,4	428	510	30	35	55	70	579	460	195	-	150	121	38	-	8,4	74	11,8	P-84 ³⁾
38,1	210	308	163	320	195	-	671	25	270	175	650	92	-	-	80	-	27,7	P-462
38,1	210	308	163	320	195	-	671	25	270	175	650	92	89	68	80	-	27,7	P-464 ³⁾

▼ Shown from left to right: P-25, P-51, P-18



When Less Than 700 Bar is All You Need



GA45GC Gauge Adaptor

Protect yourself from system overloading by simply ordering one part number for a pre-assembled gauge, adaptor block and coupler.

Page: 134



Hoses

Enerpac offers a complete line of high quality hydraulic hoses. To ensure the integrity of your system,

specify only genuine Enerpac hydraulic hoses.

Page: 122

- P-25 and P-50 pump oil in both forward and reverse handle movement improving overall efficiency, ideal when mounting space is restricted
- External load-release valve
- Internal pressure-relief valve for overload protection
- For use with single-acting cylinders and tools.

▼ P-18 hand pump used for locking the rotating table for marble polishing.



Pump Type	Usable Oil Capacity (cm ³)	Model Number *	Pressure Rating (bar)	Oil Displacement per Stroke (cm ³)	Max. Handle Effort (kg)
Single-Speed	360	P-18	200	2,46	16
	3277	P-25	175	9,50	27
	3277	P-50	350	4,75	27
	819	P-51	200	4,10	27

* For use with single-acting cylinders and tools

Low Pressure Hand Pumps

P Series



Reservoir Capacity:
360 - 3277 cm³

Flow at Rated Pressure:
2,46 - 9,50 cm³/stroke

Maximum Operating Pressure:
175 - 350 bar

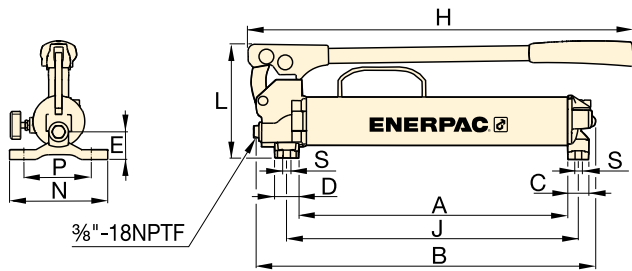

P-18

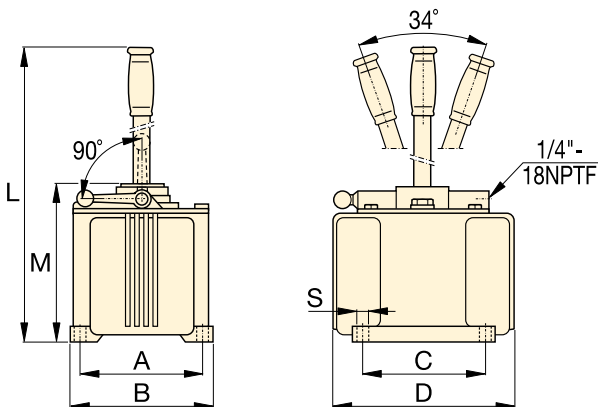

P-25, P-50

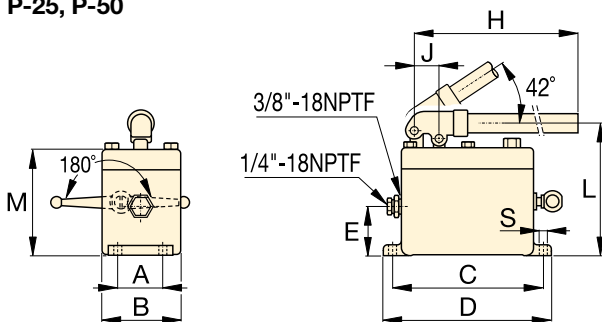

P-51



MP-Series Multifluid Hand Pumps

Corrosion resistant hand pumps for low pressure filling and high pressure testing applications, suitable for a wide range of fluids.

Page: 78

▼ P-51 hand pumps used with RC-series cylinders to keep wooden layers under pressure during lamination of plates.



Piston Stroke	Dimensions (mm)												Model Number *
	(mm)	A	B	C	D	E	H	J	L	M	N	S	
25,4	221	316	30	35	37	385	254	163	-	140	8,4	5,0	P-18
38,1	152	173	152	240	-	-	-	684	200	-	10	16,3	P-25
38,1	152	173	152	240	-	-	-	684	200	-	10	16,8	P-50
25,4	52	92	181	200	57	610	29	160	129	-	9	5,4	P-51

MP-Series, Multifluid Hand Pumps

▼ Shown: **MP-110**



- Superior corrosion resistance
- Standard Nitrile seals – can be used for a wide range of fluids such as demineralised water, oil/water emulsions, waterglycols, mineral oils
- Two speed pumps up to 1000 bar pressure
- Buna Nitrile seals can be exchanged with optional EPDM seal for use with Skydrol or brake fluids
- Impregnated aluminium anodized pump housing with stainless steel internal pumping components
- Externally adjustable pressure relief valve
- 1/4" NPTF gauge port
- For use with single-acting cylinders and tools.

MP Series

Flow at Rated Pressure:

1,6 - 20,6 cm³/stroke

Maximum Operating Pressure:

110 - 1000 bar



Optional Reservoir Kit

Includes 10 litres tank with skid frame, top plate with reservoir seal, suction pipe and mounting bolts.

Useable oil capacity is 7,4 litres. Order model number: **MP-10T**.



Stainless Steel Hand Pump

Also available as stainless steel hand pump, model number **11-400**.

Page: **80**

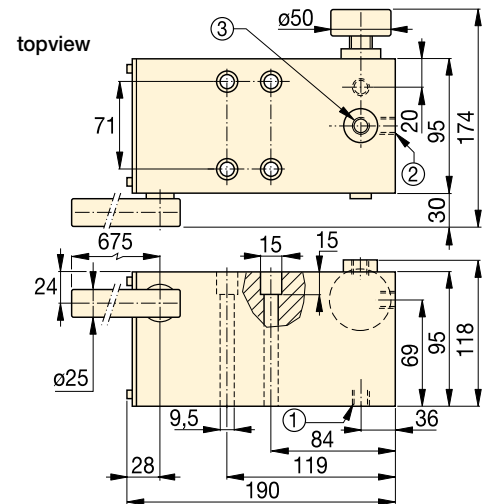

MP-110, 350, 700, 1000

- ① Suction / Tank return port 3/8"-18 NPTF
- ② Pressure port 3/8"-18 NPTF
- ③ Gauge port 1/4"-18 NPTF

Pump Type	Usable Oil Capacity * (cm ³)	Model Number **	Pressure Rating (bar)		Oil Displacement per Stroke (cm ³)		Max. Handle Effort (kg)	Piston Stroke (mm)	Weight (kg)
			1st stage	2nd stage	1st stage	2nd stage			
Two Speed	*	MP-110	35	110	52,6	20,60	45	27,1	6,6
	*	MP-350	35	350	52,6	7,15	45	27,1	6,6
	*	MP-700	35	700	52,6	2,63	45	27,1	6,6
	*	MP-1000	35	1000	52,6	1,60	45	27,1	6,6

* MP-Pump includes 1,5 mm thick gasket for reservoir mounting. MP-Series pumps requires the use of an external reservoir.

** MP-Series pumps are for use with single-acting cylinders and tools.

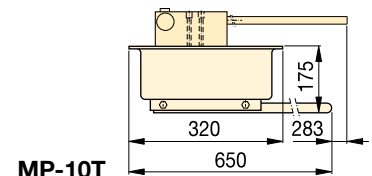
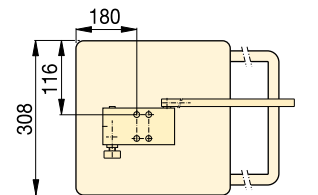

Lightweight Hydraulic Foot Pump

▼ Shown: P-392FP



- Robust, durable and compact
 - Steel frame for maximum stability
 - Steel pumping handle
 - Aluminium reservoir
- Foot pedal lock and lightweight construction for easy carrying
- Two-speed operation reduces foot pedal strokes
- Large foot-pad release valve for controlling load descent
- Internal pressure relief valve for overload protection.

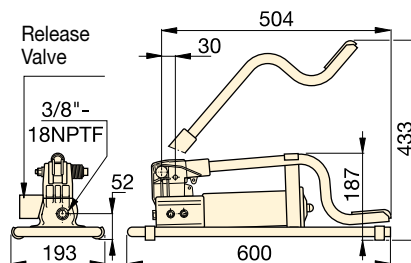

Usable Oil Capacity (cm ³)	Model Number	Pressure Rating (bar)		Oil Displacement per Stroke (cm ³)		Max. Handle Effort (kg)	Piston Stroke (mm)	Piston Weight (kg)
		1st stage	2nd stage	1st stage	2nd stage			
492	P-392FP *	15	700	11,26	2,47	42	25,4	7,0

* Available as set, see note on this page.

P Series



Reservoir Capacity:

492 cm³

Flow at Rated Pressure:

2,47 cm³/stroke

Maximum Operating Pressure:

700 bar

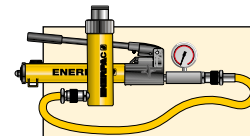

Pump-Cylinder Sets

The P-392FP is available as **set** (pump, cylinder, gauge, couplers and hose) for your ordering convenience.

Page: 58



Hoses

Enerpac offers a complete line of high quality hydraulic hoses. To ensure the integrity of your system, specify only genuine Enerpac hydraulic hoses.

Page: 122

▼ P-392FP offers the advantage of hands free operation to handle and control the tool or cylinder.



Ultra-High Pressure Hand Pumps

▼ Shown from left to right: 11-100, P-2282



- Two-speed operation on the P-2282 allows for faster fill operation, reducing cycle times for many testing applications
- 303 Stainless steel construction on the 11-100 and 11-400 models enable use with many different fluids, such as distilled water, diesters, silicones, soluble oils and petroleum
- Large release knob for improved control of pressure release
- Outlet ports are 3/4"-16 cone for 2800 bar rating
- Ultra-high pressure fittings feature all stainless steel construction except adaptor 41-366 which features nickel plated carbon steel construction.

Ultra-High Pressure up to 2800 bar



2-Way Shut-Off Valve Model Nr. 72-750

For 2800 bar applications requiring a shut-off valve or gauge snubber.

Made of 318 Stainless Steel and utilizing .38 inch cone fittings, it is the perfect selection for use with your ultra-high pressure hand pump.



Test System Gauges

Ideal for monitoring pressure in your hydraulic circuit.

Test System Gauges, such as the **T6010L**, are available with cone threads or NPTF threads and a variety of pressure ranges.

Page: 132

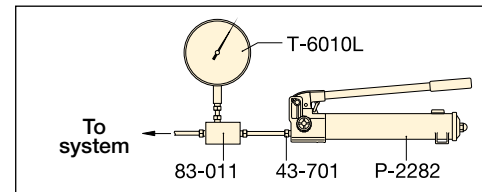

▲ Typical Test System

Cone Seal

Stainless Steel High Pressure fittings seal on a 'cone' surface and do not require pipe sealer. The Gland Nut holds the sleeve and tubing tight against the cone surface to provide a 2800 bar seal.

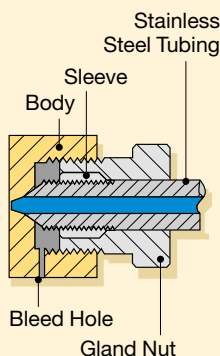

Pump Type	Usable Oil Capacity (cm ³)	Model Number	Pressure Rating * (bar)		Oil Displacement per Stroke (cm ³)		Max. Handle Effort (kg)
			1 st stage	2 nd stage	1 st stage	2 nd stage	
Two-Speed	983	P-2282	13	2800	16,22	0,61	48,1
Single-Speed	737	11-100	-	700	-	2,49	54,4
	737	11-400	-	2800	-	0,62	54,4

* Contact Enerpac for applications where operating pressure is less than 10% of operating pressure.

Ultra-High Pressure Hand Pumps

▼ Optional Ultra-High Pressure Fittings and Tubings

Description	Connection	Model Nr.
2800 bar		
Gland Nut Plug	.38" cone	43-001
Elbow	.38" cone	43-200
Tee	.38" cone	43-300
Gauge Tee	.38" cone side/ .25" cone gauge port	43-301
Gauge Adaptor	.38" cone side/ .25" cone gauge port	83-011
Coupling	.38" cone	43-400
Cross	.38" cone	43-600
Gland Nut with Sleeve	.38" cone	43-701
Gauge Connector	.25" cone	43-704
Tubing	100 mm tube, O.D. .38" * 200 mm tube, O.D. .38" * 300 mm tube, O.D. .38" *	45-116 45-126 45-136
700 bar only		
Adaptor	.38" F cone to 1/4" M NPTF	41-146
	.38" F cone to 3/8" M NPTF	41-166
Adaptor	.38" F cone to 1/4" F NPTF	41-246
	.38" F cone to 3/8" F NPTF	41-266
Adaptor	.38" M cone to 3/8" F NPTF	41-366

Note: .25" cone fittings use 9/16"-18 threads, 3/8" cone fittings use 3/4"-16 threads.
* Actual tubing lengths are 19 mm less than nominal size shown. These dimensions make distance between centers of valves and fittings multiples of 100 mm spaces.

P 11 Series



Reservoir Capacity:
737 - 983 cm³

Flow at Rated Pressure:
0,61 - 2,49 cm³/stroke

Maximum Operating Pressure:
700 - 2800 bar



Ultra-High Pressure pumps DO NOT have an internal safety pressure relief valve.



Stainless Steel Construction

Ultra-high Pressure Fittings feature all stainless steel construction except adaptor 41-366, which features nickel plated carbon steel construction.

11-100
11-400

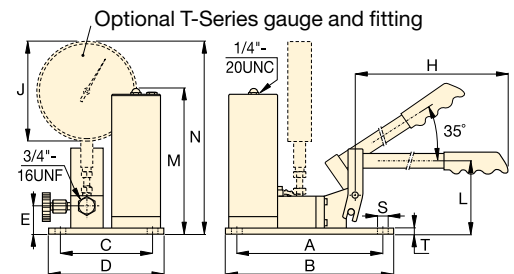

P-2282

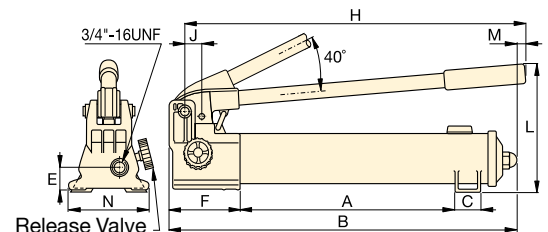

Piston Stroke	Dimensions (mm)														Model Number
	(mm)	A	B	C	D	E	F	H	J	L	M	N	S	T	
25,4	344	558	35	–	31	133	527	29	228	7	120	–	–	6,4	P-2282
19,8	240	266	151	177	45	–	635	162	114	237	314	7	9	10,0	11-100
19,8	240	266	151	177	45	–	635	162	114	237	314	7	9	10,0	11-400

▼ Shown: XC-1201ME



- **Lightweight design with integrated handle and carrying strap for portability**
- **Bladder reservoir prevents contamination and allows pump usage in any position**
- **Powerful 0,37 kW motor and 28 Volt Lithium-Ion battery deliver exceptional speed and run time**
- **High-strength fiberglass reinforced composite shroud for superior durability in demanding job site environments**
- **Cordless technology eliminates tripping hazards found in other electric or air powered pumps**
- **Available in both single-and double-acting valve configurations.**



Performance of a Powered Pump

Portability of a Hand Pump



GA45GC Gauge Adaptor Assembly

Protect yourself from system overloading by simply ordering one part number for a pre-assembled gauge, adaptor block and coupler.

Page: **134**



Battery packs contain no cadmium, so they are environmentally friendly. Enerpac encourages recycling.



28-Volt Battery

The XC-28V with Lithium-Ion technology for maximum battery performance.



Battery Charger

1-hour quick charger.

Model Nr.	Voltage
XC-115VC	115 VAC
XC-230VC	230 VAC



3/8" Swivel Connector

Customer installed 360 degree swivel coupler for optimal orientation of the hydraulic hose. See details on page 127.

Order Model Number ¹⁾ **XSC1**

¹⁾ Accessories must be ordered separately.

◀ Portable power and simplicity for the toughest jobs.



XC-Series Cordless Hydraulic Pumps

The XC-Series cordless pump is ideal for jobs that require a combination of portability, speed, and safety. These cordless pumps are perfect for remote locations without access to power, but also indoors where trip hazards, ergonomics or size is a concern.

The XC-Series cordless pump is compatible with all Enerpac hydraulic tools and small to medium sized cylinders.

The XC-Series cordless pump is CSA and CE compliant.

The Lithium-Ion battery provides superior run time:

- 270 cuts of 10 mm reinforcing bar using a WHC-750 Cutter
- 112 lifts with a WR-5 Spreader
- 45 splits on M27 - 8.8 nuts using a NC-3241 Nut Cutter
- 30 times lifting with a RC-104 cylinder (10 ton, 100 mm stroke).

Note: Actual number of cycles per charge will vary depending on condition of battery, tool and ambient conditions. Battery life with double-acting tools is approximately 75% of that for comparable, single-acting tools.



- ① Outlet "Advance" Port 3/8"-18 NPTF
- ② Oil Fill (must use funnel)
- ③ User Adjustable Relief Valve Access Port
- ④ Directional Control Valve
- ⑤ Shoulder Strap Connection Points
- ⑥ Safety Lock Feature
- ⑦ On/Off Switch
- ⑧ Inlet "Retract" Port (double-acting models only)

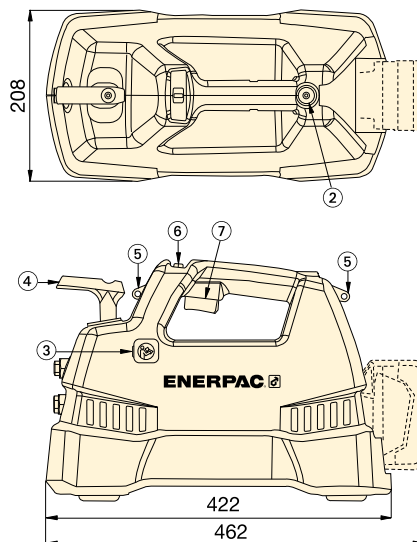
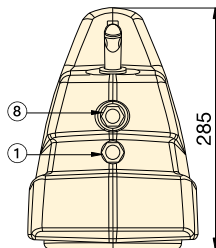

▼ SELECTION CHART

Pump Type (Used with cylinder)	Useable Oil Capacity (litres)	Model Number	Output Flow Rate (l/min)			Valve Function	Charger Voltage (VAC)	Weight (kg)
			No Load	140 bar	700 bar			
Single-Acting	1,0	XC-1201MB ¹⁾	2,0	0,50	0,25	3-way, 2-pos.	115	10
	2,0	XC-1202MB	2,0	0,50	0,25	3-way, 2-pos.	115	11
	1,0	XC-1201ME ¹⁾	2,0	0,50	0,25	3-way, 2-pos.	230	10
	2,0	XC-1202ME	2,0	0,50	0,25	3-way, 2-pos.	230	11
	1,0	XC-1201M ²⁾	2,0	0,50	0,25	3-way, 2-pos.	–	10
	2,0	XC-1202M ²⁾	2,0	0,50	0,25	3-way, 2-pos.	–	11
Double-Acting	1,0	XC-1401MB	2,0	0,50	0,25	4-way, 3-pos.	115	10
	2,0	XC-1402MB	2,0	0,50	0,25	4-way, 3-pos.	115	11
	1,0	XC-1401ME	2,0	0,50	0,25	4-way, 3-pos.	230	10
	2,0	XC-1402ME	2,0	0,50	0,25	4-way, 3-pos.	230	11
	1,0	XC-1401M ²⁾	2,0	0,50	0,25	4-way, 3-pos.	–	10
	2,0	XC-1402M ²⁾	2,0	0,50	0,25	4-way, 3-pos.	–	11

¹⁾ Available as a cylinder pump set, see page 58.

²⁾ Batteries and charger not included.

XC Series



Reservoir Capacity:

1,0 - 2,0 litres

Flow at Rated Pressure:

0,25 l/min

Maximum Operating Pressure:

700 bar

OIL FLOW vs. PRESSURE

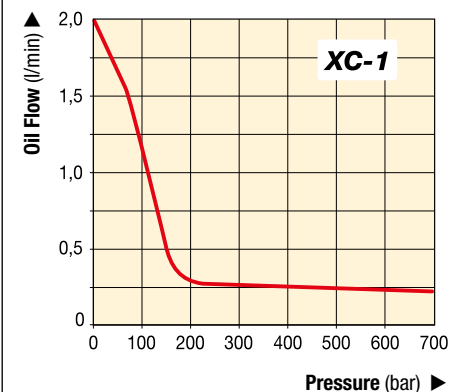

▼ Take the battery pump anywhere without power cords or air hoses.



▼ Shown: PUJ-1200E



Heavy on Performance, Light on Weight

- Lightweight and compact design: 11,8 to 18,6 kg
- Large easy-carry handle for maximum portability
- Two-speed operation reduces cycle times for improved productivity
- 230 VAC 50/60-cycle universal motor will operate under poor voltage supply
- 24 VAC remote motor control, 3 m length for operator safety
- Starts under full load
- High strength molded shroud, with integral handle, protects motor from contamination and damage
- Designed for intermittent duty cycle.

▼ An Economy Pump PUJ-1200E is used with a low-height cylinder RCS-302 to reposition a Scissor lift to simplify maintenance.



Gauges

Minimize the risk of overloading and ensure long, dependable service from your equipment. For use with the Economy pump the **G-2535L** gauge and **GA-3** gauge adaptor are suggested.

For a full range of gauges, please refer to the System Components section.

Page: 130



Hoses

Enerpac offers a complete line of high quality hydraulic hoses. To ensure the integrity of your system, specify only genuine Enerpac hydraulic hoses.

Page: 122



Speed Chart

To determine how a specific pump will operate your cylinder, see the Pump-Cylinder Speed Chart in the 'Yellow Pages'.

Page: 273

Pump Type (Used with cylinder)	Usable Oil Capacity (litres)	Model Number *	Pressure Rating (bar)	
			1 st stage	2 nd stage
Single-Acting	1,9	PUD-1100E	13	700
	3,8	PUD-1101E	13	700
	1,9	PUJ-1200E	13	700
	3,8	PUJ-1201E	13	700
	1,9	PUD-1300E	13	700
	3,8	PUD-1301E	13	700
Double-Acting	1,9	PUJ-1400E	13	700
	3,8	PUJ-1401E	13	700

* For 115 volt applications replace 'E' suffix with 'B'.

** Electric dump valve for auto-retract of cylinders.

Economy Electric Pumps



About the Economy Pump

The Economy pump is best suited to power small to medium size cylinders or hydraulic tools. Its lightweight and compact design make it ideal for applications which require easy transport of the pump. The universal motor works well on long extension cords or generator-driven electrical power supplies.

For further application assistance refer to the 'Yellow Pages'.

PUD-1100 Series

- Provides advance-retract of single-acting cylinders
- Ideal for punching applications
- For applications not requiring load holding
- 3 m cord with pendant controls motor and valve operation.

PUD-1300 Series

- Provides advance-hold-retract of single-acting cylinders
- Ideal for applications requiring load-holding
- For applications requiring solenoid valve operations
- 3 m cord with pendant controls motor and valve operation.

PUJ Series

- Manual valves provide advance-hold-retract tool operation
- Available with 3- and 4-way valves for single or double-acting cylinders
- 3 m cord with pendant controls the motor operation.



Page: 263

PU Series



Reservoir Capacity:

1,9 - 3,8 litres

Flow at Rated Pressure:

0,32 l/min

Motor Size:

0,37 kW

Maximum Operating Pressure:

700 bar

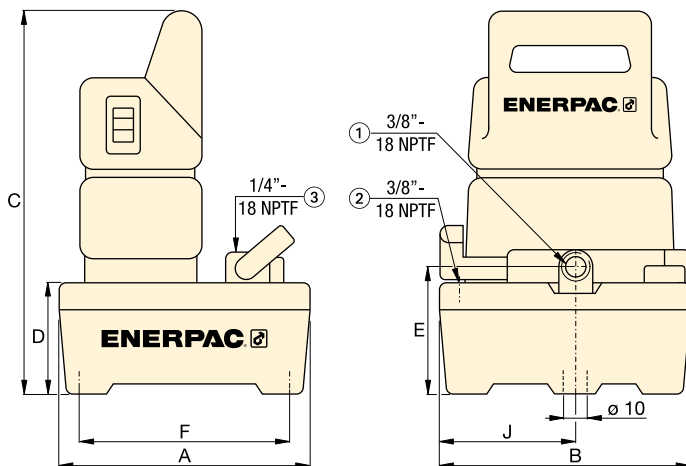

- ① Oil Outlet Port
- ② Tank Port
- ③ Gauge Port (PUJ-1200 and PUJ-1201 models only)

OIL FLOW VERSUS PRESSURE

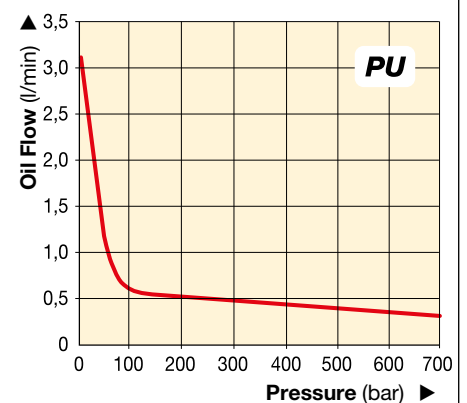

Output Flow Rate (l/min)	Valve Type	Valve Function	Current Draw (Amps)	Motor Voltage (VAC)	Sound Level (dBA)	Dimensions (mm)								Weight (kg)	Model Number *
						1 st stage	2 nd stage	A	B	C	D	E	F		
3,31	Dump**	Advance/Retract	3,2	230	85	244	244	362	101	119	203	133	11,8	PUD-1100E	
0,32			3,2	230	85	368	309	373	105	130	323	142	17,2	PUD-1101E	
3,31	3/2 manual	Advance/ Hold/Retract	3,2	230	85	244	244	362	101	119	203	133	10,0	PUJ-1200E	
0,32			3,2	230	85	368	309	373	105	130	323	142	15,4	PUJ-1201E	
3,31	3/2 solenoid	Dump & Hold	3,2	230	85	244	244	362	101	119	203	133	12,0	PUD-1300E	
0,32			3,2	230	85	368	309	373	105	130	323	142	17,5	PUD-1301E	
3,31	4/3 manual	Advance/ Hold/Retract	3,2	230	85	244	244	362	101	119	203	133	13,2	PUJ-1400E	
0,32			3,2	230	85	368	309	373	105	130	323	142	18,6	PUJ-1401E	

▼ Shown: PEJ-1401E



Best Performance for Mid-Range Cylinders and Tools

- Two-speed operation reduces cycle times for improved productivity
- Powerful 0,37 kW induction motor is submerged in the oil reservoir to run cooler, protect the motor, simplify the pump interface, save space and reduce noise
- Large 5,5 litres reservoir allows operation of a wide range of cylinders
- 24 VDC remote pendant control on certain models for improved safety
- Externally adjustable relief valve allows control of operating pressure without opening the pump
- 40-micron internal return line filter keeps oil clean, promoting longer pump life
- Full length side tube for easy monitoring of oil level.

▼ SELECTION CHART

For more technical information see next page.

5 BASIC PUMP TYPES

Select the model that suits your application. For special requirements see page 89 or contact your Enerpac office.

PEM Series: with Manual Valve

- Ideal choice for most applications
- Manual valve control, for both single-acting and double-acting applications
- Manual motor control.

PER Series: with Solenoid Valve

- Ideal for production and lifting
- All valves are 3 position for Advance-Hold-Retract
- Control pendant with 3 m cord for remote valve operation.

PEJ Series: with Remote Jog

- For light production and lifting applications
- Manual valve control for single-acting or double-acting cylinders
- Control pendant with 3 m cord for remote motor operation.

PES Series: with Pressure Switch

- Designed for continuous pressure applications, such as clamping, workholding and testing
- All versions include manual valves for directional control.



◀ The Remote Jog model (PEJ-Series) of the Submerged Pump simplifies maintenance on this machine.

Submerged Electric Pumps



PE-Series Submerged Pump Application

The Submerged pump is best suited to power small to medium size cylinders or hydraulic tools, or whenever quiet, intermittent duty cycle is needed.

With its low sound level and the addition of the optional oil cooler, the Submerged pump is suited to light production work as well.

Its lightweight and compact design also make it ideal for applications which require some transport of the pump.

For further application assistance see the 'Yellow Pages' or contact your local Enerpac office.

Page: 263

PE Series



Reservoir Capacity:

5,5 litres

Flow at Rated Pressure:

0,27 l/min

Motor Size:

0,37 kW

Maximum Operating Pressure:

700 bar

Pump Type	Used with Cylinder	Valve Function	Valve Type	Usable Oil Capacity (litres)	Model Number 230 VAC, 1 ph *	Weight (kg)
	Single-Acting	Advance/Retract	Manual, 3-way, 2-position	5,5	PEM-1201E	24,0
	Single-Acting	Advance/Hold/Retract	Manual, 3-way, 3-position	5,5	PEM-1301E	24,0
	Double-Acting	Advance/Hold/Retract	Manual, 4-way, 3-position	5,5	PEM-1401E	24,0
	Single-Acting	Advance/Hold/Retract	Solenoid, 3-way, 3-position	5,5	PER-1301E	29,5
	Double-Acting	Advance/Hold/Retract	Solenoid, 4-way, 3-position	5,5	PER-1401E	29,5
	Single-Acting	Advance/Retract	Manual, 3-way, 2-position	5,5	PEJ-1201E	24,9
	Single-Acting	Advance/Hold/Retract	Manual, 3-way, 3-position	5,5	PEJ-1301E	24,9
	Double-Acting	Advance/Hold/Retract	Manual, 4-way, 3-position	5,5	PEJ-1401E	24,9
	Single-Acting	Advance/Retract	Manual, 3-way, 2-position	5,5	PES-1201E	28,1
	Double-Acting	Advance/Hold/Retract	Manual, 4-way, 3-position	5,5	PES-1401E	28,1

* For 115V replace suffix "E" with "B" in the model number.

PE-Series, Submerged Electric Pumps

◀ For full features see previous page.

SUBMERGED PUMP PERFORMANCE							
Motor Size (kW)	Pressure Rating (bar)		Output Flow Rate at 50 Hz (l/min)		Motor Electrical Specifications *	Sound Level (dBA)	Relief Valve Adjustment Range (bar)
	1 st stage	2 nd stage	1 st stage	2 nd stage			
0,37	70	700	2,0	0,27	13 @ 115-1-50/60 6,75 @ 230-1-50/60	62-70	70-700

* At full load. See ordering matrix footnote for frequency notations.

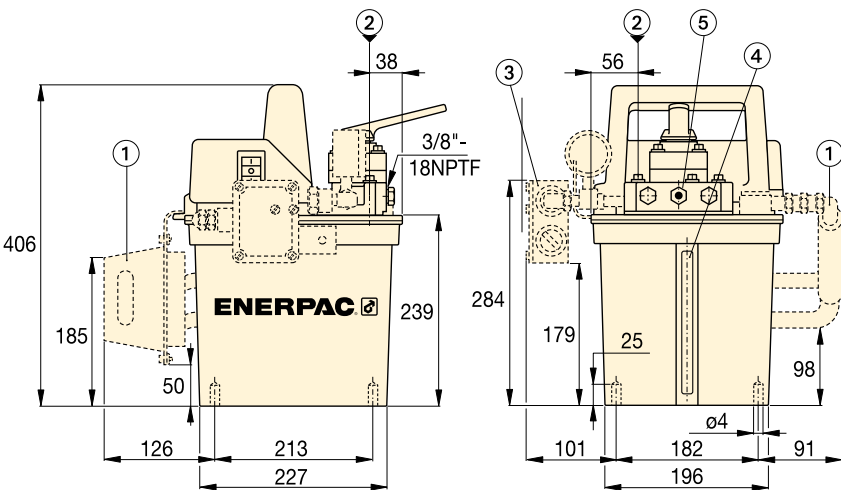

- ① Heat Exchanger (optional for all models)
- ② Fill Port
- ③ Pressure Switch (PES-series, optional for other models)
- ④ Oil Level Indicator
- ⑤ Adjustable relief valve

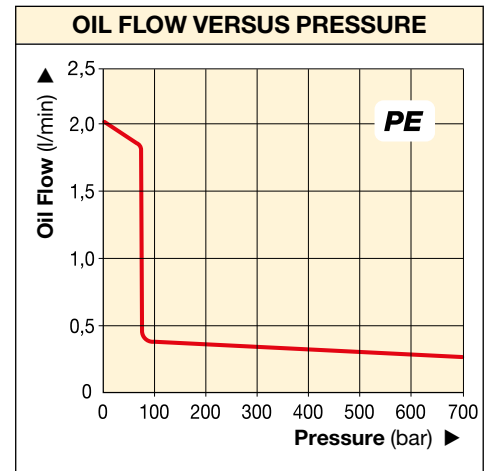

Speed Chart

To determine how a specific pump will operate your cylinder, see the Pump-Cylinder Speed Chart in the 'Yellow Pages'.

Page: 273



◀ This Submerged pump quickly and quietly powers a hydraulic nut cutter in this maintenance application.

Submerged Electric Pumps

CUSTOM BUILD YOUR SUBMERGED PUMP

If the Submerged Pump that would best fit your application cannot be found in the chart on page 87, here you can easily build your custom submerged pump.

▼ This is how a Submerged Pump Model Number is built up:

P	E	M	-	1	3	01	E
1	2	3		4	5	6	7
Product Type	Motor Type	Pump Type		Pump Series	Valve Type	Reservoir Size	Motor Voltage

1 Product Type

P = Pump

2 Motor Type

E = Electric Motor

3 Pump Type

J = Jog

M = Manual

R = Remote (Solenoid) ^{1) 2)}

S = Pressure Switch

4 Pump Series

1 = 0,37 kW, 700 bar

5 Valve Type

0 = No valve (PER only)

2 = 3-way, 2-position, normally open

3 = 3-way, 3-position, tandem center

4 = 4-way, 3-position, tandem center

5 = Modular solenoid valve (PER only)

6 Reservoir Capacity

01 = 5,5 litres

7 Motor Voltage and Heat Exchanger

B = 115 V, 1 Ph, 50/60 Hz ¹⁾

D = 115 V, 1 Ph, 50/60 Hz ¹⁾ with Heat Exchanger

E = 230 V, 1 Ph, 50/60 Hz ²⁾

F = 230 V, 1 Ph, 50/60 Hz ²⁾ with Heat Exchanger

I = 230 V, 1 Ph, 60 Hz

¹⁾ Solenoid valves operate only at 60 Hz. Can run on 50 Hz with manual valves.

²⁾ Solenoid valves operate only at 50 Hz. Can run on 60 Hz with manual valves.

The following submerged pump models include a modular solenoid valve and pilot operated check valve:

PER-1301B

PER-1301D

PER-1301E

PER-1401B

PER-1401D

PER-1401E

Ordering Example

Model Number: PER-1301E

The PER-1301E is a 0,37 kW, 700 bar, submerged electric pump, with 5,5 litres usable oil capacity, a 3-way, 3-position, remote solenoid valve and a 230 V, 1 Phase, 50/60 Hz motor.

PE Series



Reservoir Capacity:

5,5 litres

Flow at Rated Pressure:

0,27 l/min

Motor Size:

0,37 kW

Maximum Operating Pressure:

700 bar



Hoses

Enerpac offers a complete line of high quality hydraulic hoses. To ensure the integrity of your system, specify only genuine Enerpac hydraulic hoses.

Page: **122**



Gauges

Minimize the risk of overloading and ensure long, dependable service from your equipment. Refer to the System Components section for a full range of gauges.

Page: **130**

Z-Class Enerpac Power Pumps

Introducing the **Z-Class** power pumps from Enerpac – pumps that run cooler, use less electricity and are easy to service.

Enerpac has used the latest metallurgical, bearing and seal technologies to produce a pump whose features and benefits far surpass the electric pumps that are available today. By reducing the number of moving parts, improving flow dynamics and decreasing friction, Z-Class pumps will stay on the job longer, require less energy to operate and when needed, have lower service costs.



Z-Class power pumps from Enerpac – simply the best pump you will ever use.

Z Tough.
Dependable.
Innovative.
CLASS



Z-Class, An Innovation in Pump Design

Z-Class Pumping Element – The Heart of Your Hydraulic System

Highly efficient design provides increased flow rates, reduced heat generation and a decrease in power consumption. This means improved tool speed and increased service life – which results in higher productivity and lower operating costs.

Heavy-duty bearings extend pump life by reducing friction, reducing surface-loading and lowering bearing stresses.

Pump cavity oil bath extends pump life by reducing heat, improving lubrication and reducing wear.

Self-priming, high-flow 1st stage pump increases pump performance by super-charging the 2nd stage piston pump – improving oil flow in both hot and cold weather operation.

Balanced rotating components reduce vibration creating a smoother running pump – reducing wear, friction and sound levels.

Replaceable piston check-valves increase service life of major pump components.

Ergonomic pendant features sealed switches and operates at 24 V for improved operator safety.

Z-Class factory options & accessories

Extensive list of accessories including heat exchanger, roll cage, skid bar, pressure transducer, return line filter and level and temperature switches, allow complete pump control over a wide range of industrial applications.

Z-Class power pumps for your application

Available in one flow range for universal motor and eight flow ranges for induction motor. Choose from single or two-stage models to provide the optimum cylinder and tool performance for almost any industrial application.

Back-lit LCD on select Z-Class pumps

- pump usage information, hour and cycle counts
- low-voltage warning and recording
- offers self-test and diagnostic capabilities
- information displayed in 6 languages
- pressure read-out (when used with the optional pressure transducer)
- adjustable trigger pressure setting (when used with the optional pressure transducer).



Back-lit LCD available on ZU and ZE-Series Electric Pumps. ▶



ZU-Series Pump Applications

- **Mobile:** when frequent pump transport is required and/or on remote locations
- **Universal motor:** 1-phase, runs well under poor voltage supply, using generator power supply or using long extension cord
- **Duty-cycle:** for intermittent applications
- **Cylinders and tools:** for medium to large size single and double-acting applications and high speed
- **Pump speed:** two stage pump unit.



ZE-Series Pump Applications

- **Stationary:** when pump remains in one location
- **Induction motor:** 1 and 3-phase for high cycle usage
- **Duty-cycle:** for heavy-duty, extended cycle application
- **Cylinders and tools:** for medium to large size single and double-acting applications and high speed
- **Pump speed:** single or two stage pump unit.

Oil Flow Rate at 700 bar (l/min)	Z-Class Pump Series *	Electric Motor Power (kW)	Air Motor-Consumption (l/min)	Gasoline Engine Power (kW)	Page:
0,55	ZE3	0,75	–	–	98
0,82	ZE4(T)	1,12	–	–	98, 220
1,00	ZU4(T)	1,25	–	–	92, 216
1,30	ZA4(T)	–	2840	–	110, 224
1,60	ZG5	–	–	4,8	112
1,64	ZE5(T)	2,24	–	–	98, 220
2,73	ZE6	5,60	–	–	98
3,30	ZG6	–	–	9,7	112

* ZA4T, ZU4T, ZE4T and ZE5T-Series are Torque Wrench Pumps.

ZU4-Series, Portable Electric Pumps

▼ Shown from left to right: ZU4304ME, ZU4420SE-H, ZU4304PE-K



- High-efficiency two-speed pump design – higher oil flow and bypass pressure
- Powerful 1,25 kW universal electric motor provides high power-to-weight ratio and excellent low-voltage operating characteristics
- High-strength, moulded composite shroud protects motor and electronics, while providing an ergonomic, non-conductive handle for easy transport.

Pro-Series models only

- * Back-lit LCD readout provides pressure display and a number of diagnostics and readout capabilities never offered on a portable pump before:
 - pump usage information, hour and cycle counts
 - self-test, diagnostic and read-out capabilities
 - pressure readout and auto-mode pressure settings.



◀ Designed to be tough, the ZU4-Series with steel reservoirs will take the abuse of today's construction sites.

Z Tough.
Dependable.
Innovative.
CLASS



Assisted Return Pumps with Venturi Valve Technology

To improve productivity and plunger retraction, Enerpac offers valve configurations designed to accelerate your cylinder retraction speeds, ZU4-Series pumps feature **Venturi Valve Technology** to facilitate the faster return of single-acting gravity return cylinders. See valve type in ordering matrix and details in section Directional Control Valves.

▼ COMMON PUMP MODELS

For technical information and other options see next page.

BASIC PUMP TYPES

Select the model that suits your application. For special requirements contact your Enerpac office.

Manual Valve

- Ideal choice for most applications.
- For single-acting or double-acting applications.
- Venturi Valve Technology (VM33VAC) for faster retract of single-acting cylinders.
- Motor control on shroud.

Manual Valve with Pendant *

- For light production and lifting applications.
- For single- or double-acting cylinders.
- Venturi Valve Technology (VM33VAC) for faster retract of single-acting cylinders.
- Manual valve with power seat (VM43LPS), ideal for post-tensioning applications.

Dump Valve *

- Ideal for punching, crimping and cutting.
- For use when load-holding is not required.

Solenoid Valve *

- Ideal for lifting applications and where remote control is required.
- Venturi Valve Technology (VE33VAC) for faster retract of single-acting cylinders.
- With VE32 valve, motor only runs during the advance function, while holding and retracting, the motor is off.
- Motor runs continuously on pumps with VE33 and VE43 valves.

* Pendant with 3 m. cord controls valve and motor.

ZU4-Series, Electric Pumps



Z-Class – A Pump For Every Application

Patented Z-Class pump technology provides high by-pass pressures for increased productivity – important in applications using long hose runs and high pressure-drop circuits, like heavy lifting or certain double-acting tools.

Enerpac ZU4-Series Pumps are built to power small to large-sized cylinders or hydraulic tools, or wherever high-speed, intermittent duty, remote hydraulic power is needed.

Classic Electric Pumps

- The Classic has traditional electro-mechanical components (transformers, relays and switches) in place of solid-state electronics.

The Classic delivers durable, safe and efficient hydraulic power for demanding markets like construction, post-tensioning and foundation repair.

Standard Electric Pumps

- For applications that do not require digital display features of the Premium Pump. Available in all manual or jog versions.

Pro Electric Pumps

- Digital (LCD) display features a built-in hour meter and shows self-diagnostic, cycle-count and low voltage warning information.
- Pressure can also be displayed when the pump is equipped with an optional pressure transducer.



ZU4 Series



Reservoir Capacity:

4 - 40 litres

Flow at Rated Pressure:

1,0 l/min

Motor Size:

1,25 kW

Maximum Operating Pressure:

700 bar

Pump type	Used with Cylinder		Valve Function			Valve Type ¹⁾	Pump Control	Useable Oil Capacity (litres)	Model Number 230 V - 1 phase - 50 Hz ²⁾			Pro Electric Weight ³⁾ (kg)
									Classic Electric	Standard (STD) Electric	Pro Electric (incl. LCD)	
	●		●		●	VM32	Manual	4,0	ZU4204RE	ZU4204ME	ZU4204LE	27
	●		●		●	VM32	Manual	8,0	ZU4208RE	ZU4208ME	ZU4208LE	32
	●		●	●	●	VM33VAC	Manual	8,0	ZU41008RE	ZU41008ME	ZU41008LE	33
	●		●	●	●	VM33	Manual	20,0	ZU4320RE	ZU4320ME	ZU4320LE	50
		●	●	●	●	VM43	Manual	8,0	ZU4408RE	ZU4408ME	ZU4408LE	32
		●	●	●	●	VM43	Manual	20,0	ZU4420RE	ZU4420ME	ZU4420LE	50
	●		●		●	VM32 ⁴⁾	Remote (Man.)	4,0	ZU4704PE ⁴⁾	ZU4204JE	ZU4204KE	27
	●		●		●	VM33VAC	Remote (Man.)	8,0	ZU41008PE	ZU41008JE	ZU41008KE	33
	●		●		●	VM32 ⁴⁾	Remote (Man.)	20,0	ZU4720PE ⁴⁾	ZU4220JE	ZU4220KE	50
	●		●	●	●	VM33	Remote (Man.)	8,0	ZU4308PE	ZU4308JE	ZU4308KE	32
		●	●	●	●	VM43	Remote (Man.)	8,0	ZU4408PE	ZU4408JE	ZU4408KE	32
		●	●	●	●	VM43	Remote (Man.)	20,0	ZU4420PE	ZU4420JE	ZU4420KE	50
	●		●		●	VE32D	Remote	4,0	N/A	N/A	ZU4104DE	29
	●		●		●	VE32D	Remote	8,0	N/A	N/A	ZU4108DE	33
	●		●		●	VE32D	Remote	20,0	N/A	N/A	ZU4120DE	51
						–	–	–	–	–	–	–
						–	–	–	–	–	–	–
						–	–	–	–	–	–	–
	●		●	●	●	VE32	Remote	4,0	N/A	N/A	ZU4204SE	29
	●		●	●	●	VE32	Remote	8,0	N/A	N/A	ZU4208SE	33
	●		●	●	●	VE33	Remote	8,0	N/A	N/A	ZU4308SE	39
	●		●	●	●	VE33VAC	Remote	8,0	N/A	N/A	ZU41108SE	40
		●	●	●	●	VE43	Remote	8,0	N/A	N/A	ZU4408SE	39
		●	●	●	●	VE43	Remote	20,0	N/A	N/A	ZU4420SE	56
						–	–	–	–	–	–	–
						–	–	–	–	–	–	–

¹⁾ See valves section for technical information on valve types. ²⁾ See custom order matrix on page 89 for other voltage options.

³⁾ Subtract 1,4 kg for Standard (STD) Electric models. ⁴⁾ ZU47... pump models have VM22 3-way, 2 position manual valve for foundation repair applications.



Pressure Transducer *

- More durable than analog gauges (against mechanical and hydraulic shock)
- More accurate than analog gauges (0,5% full scale of pump)
- Calibration can be fine tuned for certification
- "Set pressure" feature turns off motor at user defined pressure (or shifts valve to neutral on models with VE33/VE43 valves)
- Display pressure in bar, psi or MPa.

* Requires LCD Electric

Accessory Kit Model Number	Adjustable Pressure Range (bar)	Switch-point repeatability	Dead-band (bar)
ZPT-U4 *	3,5 - 700	± 0,5%	3,5

* Add suffix **T** for factory installation.



Level/Temperature Switch

- Ensures feedback on pump oil level and temperature
- Drop-in design allows for easy installation to pump reservoir
- Plugs directly into pump electrical enclosure
- Built-in thermal sensing shuts off pump when unsafe operating temperature is reached
- Oil level switch shuts down pump before oil reaches an unsafe operating level.

Model Number	Operating Temperature (°C)	Maximum Pressure (bar)	 (kg)
ZLS-U4 *	5-110	10	0,1

* Add suffix **L** for factory installation.



Hoses

Enerpac offers a complete line of high-quality hydraulic hoses. To ensure the integrity of your system, specify only Enerpac hydraulic hoses.

Page: 122



Gauges

Minimize the risk of overloading and ensure long, dependable service from your equipment. Refer to the System Components section for a full range of gauges.

Page: 130



Foot Switch

- Hands-free remote control on solenoid dump and 3-position valves
- With 3 metres cord.

Accessory Kit Modelnr.	Can be used on ZU4-Series Pumps with
ZCF-2 *	Solenoid VE-Series valves

* Add suffix **U** for factory installation.



Roll Cage

- Protects pump
- Provides greater pump stability.

Accessory Kit Modelnr.	Fits on reservoir
ZRC-04 *	4 and 8 litres ¹⁾
ZRC-04H *	4 and 8 litres ²⁾
ZRB-10 *	10 litres
ZRB-20 *	20 litres
ZRB-40 *	40 litres

* Add suffix **R** for factory installation.

¹⁾ Without heat exchanger

²⁾ With heat exchanger.



Skid Bar

- Provides easy two-hand lift
- Provides greater pump stability on soft or uneven surfaces.

Accessory Kit Modelnr.	Fits on reservoir	 (kg)
SBZ-4 *	4 and 8 l without heat exchanger	2,2
SBZ-4L *	4 and 8 l with heat exchanger	3,2

* Add suffix **K** for factory installation.

ZU4-Series, Options & Accessories



ZU4-Series Options

Accessory Kits can be installed by the customer.

See chart below for all possible options on ZU4-Series pumps:

- Classic Electric,
 - Standard (STD) Electric (no LCD)
 - Pro Electric (with LCD).
- Refer to page 97 for ordering matrix.

ZU4-Series Options	Factory Installed			Accessory Kits		
	Classic Electric	Standard Electric	Pro Electric	Classic Electric	Standard Electric	Pro Electric
Return Line Filter	F	F	F	ZPF	ZPF	ZPF
Skid Bar ¹⁾	K	K	K	SBZ	SBZ	SBZ
Roll Cage	R	R	R	ZRC	ZRC	ZRC
Heat Exchanger	H	H	H	ZHE	ZHE	ZHE
1000 bar Pressure Gauge	G	G	G	G	G	G
Pressure Transducer	-	-	T	-	-	ZPT-U4
Level/Temperature Switch	-	-	L	-	-	ZLS-U4
Foot Switch	-	-	U	-	-	ZCF-2

¹⁾ Skid Bar not in combination with Roll Cage.

ZU4 Series



Reservoir Capacity:

4 - 40 litres

Flow at Rated Pressure:

1,0 l/min

Motor Size:

1,25 kW

Maximum Operating Pressure:

700 bar



Return Line Filter

- 25 micron filter removes contaminants from return oil flow
- By-pass valve prevents damage if filter is dirty
- With maintenance indicator.

Accessory Kit Modelnr.	Maximum Pressure (bar)	Maximum Oil Flow (l/min)	By-pass Setting (bar)
ZPF *	13,8	45,4	1,7

* Add suffix **F** for factory installation.



Heat Exchanger

- Removes heat from by-pass oil to provide cooler operation
- Stabilizes oil viscosity, increasing oil life and reduces wear of pump and other hydraulic components.

Accessory Kit Nr.	Can be used on	(kg)
ZHE-U115 *	115 V pumps	4,1
ZHE-U230 *	230 V pumps	4,1

* Add suffix **H** for factory installation.



Heat Exchanger

Can be factory installed on ZU4-Series Classic, Standard Electric and Pro Electric models.

- Extends system life.
- Stabilizes oil temperature at a maximum of 54 °C at 21 °C ambient temperature.

Do not exceed maximum oil flow and pressure ratings. Heat exchanger is not suitable for water-glycol or high water based fluids.

Thermal Transfer *		Maximum Pressure	Maximum Oil Flow	Voltage
Btu/h	kJoule	(bar)	(l/min)	(VDC)
900	950	20,7	26,5	12

* At 1,9 l/min at 21 °C ambient temperature.

ZU4, Specifications and Dimensions

OIL FLOW VERSUS PRESSURE

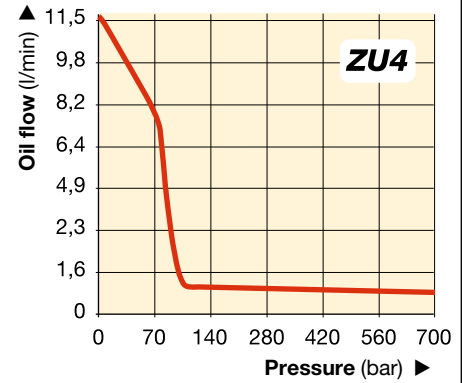

ZU4-SERIES PERFORMANCE CHART

Motor Size (kW)	Output Flow Rate at 50 Hz (l/min)				Motor Electrical Specifications (Volts-Ph-Hz)	Sound Level (dBA)	Relief Valve Adjustment Range (bar)
	7 bar	50 bar	350 bar	700 bar			
1,25	11,5	8,8	1,2	1,0	115-1-50/60 230-1-50/60	85-90	140-700

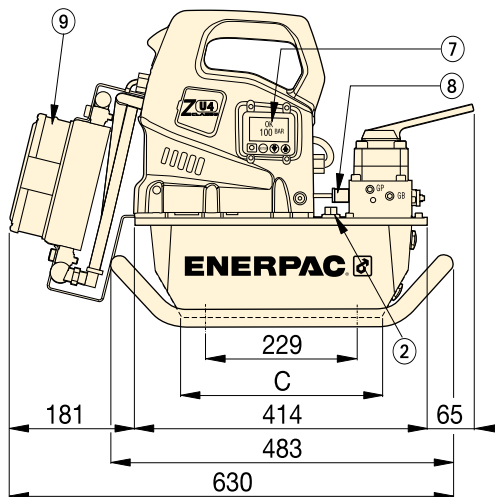

ZU4-Series with 4 and 8 litres reservoirs

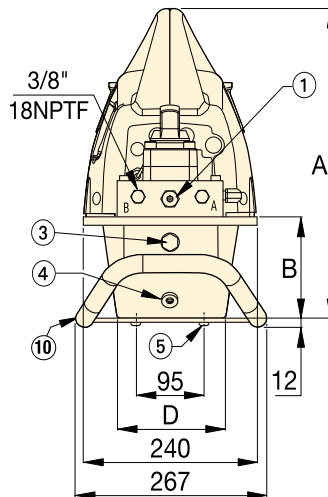

3/8"-18 NPTF Advance and Retract Ports

- ① User adjustable relief valve
- ② Oil fill port SAE #10 7/8"-14 UNF-2B
- ③ Oil level sight gauge
- ④ Oil drain 1/2" NPTF
- ⑤ M8, 6 mm deep
- ⑥ Handles on all 10, 20 and 40 litres reservoirs.

Options (see chart on page 95):

- ⑦ Back-lit LCD Electric
- ⑧ Pressure transducer
- ⑨ Heat Exchanger
- ⑩ Skid Bar
Fits 4 and 8 litres reservoirs
- ⑪ Handle guard installed on all 10, 20 and 40 litres reservoirs
- ⑫ Reservoir handles (not shown) included on all 10, 20 and 40 litres reservoirs.

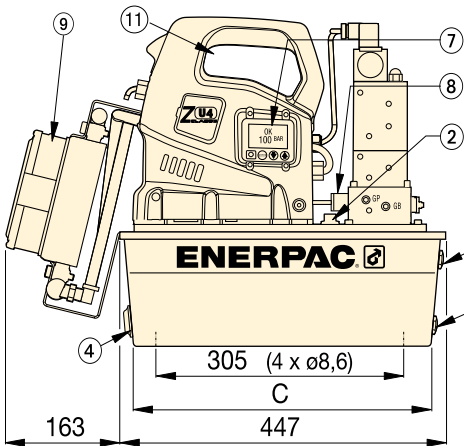

ZU4-Series with 10, 20 and 40 litres reservoirs
(left view shown without side handle)

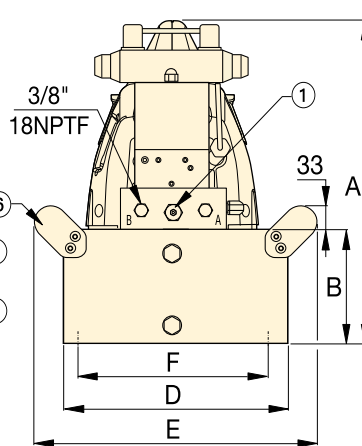

Pump Dimensions (mm)

Usable Reservoir Capacity (litres)	A	B	C	D	E	F
4,0	424	142	279	152	-	-
8,0	424	142	279	206	-	-
10,0	439	157	413	305	384	279
20,0	465	180	413	422	500	396
40,0	551	269	399	503	576	480

ZU4-Series, Pump Ordering Matrix

CUSTOM BUILD YOUR ZU4-SERIES PUMP

If the ZU4-Series pump that would best fit your application cannot be found in the chart on page 93, you can easily build your custom ZU4-Series pump here.

▼ This is how a ZU4-Series pump model number is built up:

Z	U	4	1	04	D	E	-	H	K	T
1	2	3	4	5	6	7		8		
Product Type	Motor Type	Flow Group	Valve Type	Reservoir Size	Valve Operation	Voltage		Options and Accessories		

1 Product Type

Z = Pump Series

2 Motor Type

U = Universal electric motor

3 Flow Group

4 = 1,0 l/min @ 700 bar

4 Valve Type (see page 116-117 for more details)

- 1** = Dump (**VE32D**)
- 2** = 3 way/2 position manual or electric (**VM32** or **VE32**)
- 3** = 3 way/3 position manual or electric (**VM33** or **VE33**)
- 4** = 4 way/3 position manual or electric (**VM43** or **VE43**)
- 6** = 3 way/3 position locking manual w/po check (**VM33L**)
- 7** = 3 way/2 position manual (**VM22**)
- 8** = 4 way/3 position locking manual w/po check (**VM43L**)
- 9** = 4 way/3 position manual w/power seating (**VM43LPS**)
- 10** = 3 way/3 position manual Venturi valve (**VM33VAC**)
- 11** = 4 way/3 position electric Venturi valve (**VE33VAC**)
- 12** = 3 way/3 position manual locking Venturi valve (**VM33LVAC**)

5 Reservoir Size (useable capacity)

- 04** = 4 litres
- 08** = 8 litres
- 10** = 10 litres (reservoir includes side handles)
- 20** = 20 litres (reservoir includes side handles)
- 40** = 40 litres (reservoir includes side handles)

6 Valve Operation

- D** = Dump (solenoid valve w/pendant and LCD Electric)
- J** = Jog (manual valve w/pendant and Standard Electric (i.e. w/o LCD))
- K** = Jog (manual valve w/pendant and LCD Electric)
- L** = Manual valve w/LCD Electric (w/o pendant)
- P** = Manual valve w/pendant and classic electric (i.e. w/o LCD)
- R** = Manual valve w/Classic electric (i.e. w/o LCD) [w/o pendant]
- M** = Manual valve w/Standard Electric (i.e. w/o LCD) [w/o pendant]
- S** = Solenoid valve w/pendant and LCD Electric

7 Voltage

- B** = 115V, 1 ph, 50/60Hz
- E** = 208-240V, 1 ph, 50/60 Hz (with European plug and CE EMC compliant)
- I** = 208-240V, 1 ph, 50/60 Hz (with NEMA 6-15 plug)

8 Options and Accessories (see pages 95-96 for possibilities)

- F** = Filter
- G** = 0-1000 bar pressure gauge (ø 63,5 mm) ¹⁾
- H** = Heat exchanger
- K** = Skid Bar (4 and 8 litres reservoirs only)
- L** = Level/temperature switch ^{2),3)}
- N** = No reservoir handles (includes lifting eyes)
- R** = Roll Cage
- T** = Pressure transducer ²⁾
- U** = Foot switch

¹⁾ Pressure gauge not available on pump models with pressure transducer

²⁾ These options require Pro Electric

³⁾ Not available on 4 and 8 litres reservoirs

ZU4 Series



Reservoir Capacity:

4 - 40 litres

Flow at Rated Pressure:

1,0 l/min

Motor Size:

1,25 kW

Maximum Operating Pressure:

700 bar



Speed Chart

To determine how a specific pump will operate your cylinder, see the Pump-Cylinder Speed Chart in the 'Yellow Pages'.

Page: 273



Assisted Return Pumps with Venturi Valve Technology

To improve productivity and plunger retraction, Enerpac offers valve configurations designed to accelerate your cylinder retraction speeds, ZU4 and ZE-Series pumps feature **Venturi Valve Technology** to facilitate the faster return of single-acting gravity and spring return cylinders. See valve type in ordering matrix and details in section Directional Control Valves.

Page: 116



Ordering Example: ZU4108DE-HKT

is a Pro Electric model pump with LCD, 1,0 l/min oil flow at 700 bar, pump with a dump valve, an 8 liter reservoir, operates on 230V, heat exchanger, pressure transducer and skid bar.



Spring Centred Valve Kits

VM and VC-Series manual 3-position valves can be easily converted into spring centred valves. With these retro-fit kits the handle will automatically move into the neutral valve position when released.

Page: 117

ZE-Series, Electric Pumps

▼ Shown from left to right: ZE3304ME-K, ZE4110DE-FHR













Z Tough.
Dependable.
Innovative.
CLASS

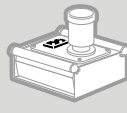
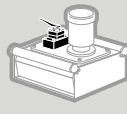

Assisted Return Pumps with Venturi Valve Technology

To improve productivity and plunger retraction, Enerpac offers valve configurations designed to accelerate your cylinder retraction speeds, ZE-Series pumps feature **Venturi Valve Technology** to facilitate the faster return of single-acting gravity return cylinders. See valve type in ordering matrix and details in section Directional Control Valves.

PUMP CONFIGURATIONS		Pump Type	Used with Tool or Cylinder		Valve Function ¹⁾			Valve ¹⁾ Model Number	Useable Oil Capacity (litres)	
For options and other model numbers see ordering matrix or contact your Enerpac office. (For Z-Class pumps with air motor see ZA-series pumps on page 110). Page: 										
No valve, without electric box ²⁾ or LCD • For remote valves or pump mounting Enerpac VM-series valves.								–	4,0	
								–	10,0	
								–	20,0	
								–	40,0	
MANUAL VALVE CONTROL	With manual valve, without electric box or LCD • Ideal choice for most application • Manual valve control, for single and double-acting applications • Venturi Valve (VM33VAC) for faster retract of single-acting cylinders. • Manual motor control • On/Off switch on 1-phase electric motor.		●	–	●	–	●	VM32	4,0	
			●	–	●	●	●	VM33	8,0	
			●	–	●	●	●	VM33VAC	10,0	
			–	●	●	●	●	VM43	20,0	
			–	●	●	●	●	VM43L	40,0	
MANUAL VALVE CONTROL	With manual valve, with electric box and LCD • For single-acting or double-acting applications • Venturi Valve Technology (VM33VAC) for faster retract of single-acting cylinders. • On/off switch on 1-phase electric motor • All options available.		●	–	●	–	●	VM32	4,0	
			●	–	●	–	●	VM32	8,0	
			●	–	●	●	●	VM33VAC	10,0	
			●	–	●	●	●	VM33L	10,0	
			–	●	●	●	●	VM43	20,0	
			–	●	●	●	●	VM43L	40,0	
REMOTE VALVE CONTROL	With solenoid dump valve, with electric box and LCD • Ideal for punching, crimping and cutting • For use when load holding is not required • Push-button pendant ³⁾ controls valve and motor • All options available.		●	–	●	–	●	VE32D	4,0	
			●	–	●	–	●	VE32D	8,0	
			●	–	●	–	●	VE32D	10,0	
			●	–	●	–	●	VE32D	20,0	
			●	–	●	–	●	VE32D	40,0	
		With solenoid 3-position valve, with electric box and LCD • Ideal for production and lifting applications • 3-position valves (advance/hold/retract) • Venturi Valve Technology (VE33VAC) for faster retract of single-acting cylinders. • Push-button pendant ³⁾ controls valve and motor • All options available.		●	–	●	●	●	VE33	4,0
				●	–	●	●	●	VE33VAC	8,0
				●	–	●	●	●	VE33	10,0
				–	●	●	●	●	VE43	10,0
				–	●	●	●	●	VE43	20,0
		–		●	●	●	●	VE43	40,0	

¹⁾ See Valve Section (page 117) for hydraulic symbols and details.

²⁾ For No Valve, with Electric Box, see ordering matrix on page 103.

³⁾ Pendant includes 3 meters cord.

ZE-Series, Electric Pumps

- High-efficiency pump design – higher oil flow and by-pass pressure
- High-strength, moulded electrical box protects electronics, power supplies and LCD readout and stands up to harsh industrial environments
- IP54 protection and isolation class
- Back-lit LCD provides self test, diagnostic and read-out capabilities never before offered on an industrial pump (included on pump with electric valves, optional on other models)
- Totally enclosed, fan-cooled industrial electric motors for extended life
- User adjustable relief valve built-in on manual and solenoid valves. Oil ports on valves are 3/8" NPTF
- Steel fan guard on all electric motors
- Full sight oil level glass on 10, 20 and 40 litres reservoirs, oil level indicators on 4 and 8 litres reservoirs.
- 40 micron filter breather with splash guard
- Durable steel reservoirs.

ZE Series



Reservoir Capacity:

4 - 40 litres

Flow at Rated Pressure:

0,55 - 2,73 l/min

Motor Size:

0,75 - 5,60 kW

Maximum Operating Pressure:

700 bar

ZE3-Series 0,55 l/min at 700 bar Two-stage pump		ZE4-Series 0,82 l/min at 700 bar Two-stage pump		ZE5-Series 1,64 l/min at 700 bar Two-stage pump		ZE6-Series 2,73 l/min at 700 bar Two-stage pump	
Model Nr. ⁴⁾ 400V / 3 phase	(kg)	Model Nr. ⁴⁾ 400V / 3 phase	(kg)	Model Nr. ⁴⁾ 400V / 3 phase	(kg)	Model Nr. ⁴⁾ 400V / 3 phase	(kg)
ZE3004NW	36	ZE4004NW	40	–	–	–	–
ZE3010NW	45	ZE4010NW	49	ZE5010NW	54	ZE6010NW	72
ZE3020NW	57	ZE4020NW	61	ZE5020NW	66	ZE6020NW	84
ZE3040NW	80	ZE4040NW	84	ZE5040NW	89	ZE6040NW	107
ZE3204MW	39	ZE4204MW	43	–	–	–	–
ZE3308MW	44	ZE4308MW	48	–	–	–	–
ZE31010MW	51	ZE41010MW	55	ZE51010MW	60	ZE61010MW	78
ZE3420MW	60	ZE4420MW	64	ZE5420MW	69	ZE6420MW	87
ZE3840MW	85	ZE4840MW	89	ZE5840MW	94	ZE6840MW	112
ZE3204LW	42	ZE4204LW	46	–	–	–	–
ZE3208LW	47	ZE4208LW	51	–	–	–	–
ZE31010LW	52	ZE41010LW	56	ZE51010LW	61	ZE61010LW	79
ZE3610LW	53	ZE4610LW	57	ZE5610LW	62	ZE6610LW	80
ZE3420LW	63	ZE4420LW	67	ZE5420LW	72	ZE6420LW	90
ZE3840LW	88	ZE4840LW	92	ZE5840LW	97	ZE6840LW	115
ZE3104DW	44	ZE4104DW	48	–	–	–	–
ZE3108DW	49	ZE4108DW	53	–	–	–	–
ZE3110DW	53	ZE4110DW	57	ZE5110DW	62	ZE6110DW	79
ZE3120DW	65	ZE4120DW	69	ZE5120DW	74	ZE6120DW	92
ZE3140DW	88	ZE4140DW	92	ZE5140DW	97	ZE6140DW	115
ZE3304SW	49	ZE4304SW	53	–	–	–	–
ZE31108SW	55	ZE41108SW	59	–	–	–	–
ZE3310SW	58	ZE4310SW	62	ZE5310SW	67	ZE6310SW	85
ZE3410SW	58	ZE4410SW	62	ZE5410SW	67	ZE6410SW	85
ZE3420SW	70	ZE4420SW	74	ZE5420SW	79	ZE6420SW	97
ZE3440SW	93	ZE4440SW	97	ZE5440SW	102	ZE6440SW	120

⁴⁾ See custom ordering matrix on page 95 for other voltages.



Adjustable Relief Valve

All VM and VE-Series have a user adjustable relief valve to allow the operator to easily set the optimum working pressure.



Locking Valves

For applications requiring positive load holding, VM-Series valves (except VM32) are available with a pilot-operated check valve. This

provides hydraulic locking of the load until the valve is shifted into the retract position. To order this feature on your ZE-series pump see the valve type in the order matrix.

Page: 103



Single or Two-Stage

Choose **single-stage** pumps for applications that require constant flow regardless of pressure such as testing or clamping.

Two-stage pumps have an increased output flow at low pressure to allow fast movement towards the load, for reduced cycle times and increased productivity.



Electric Box ¹⁾

- Back-lit LCD
- Pump usage information, hour and cycle counts
- Low-voltage warning and recording
- Self-test and diagnostic capabilities
- Pressure read-out ²⁾
- Auto-mode pressure setting ²⁾
- Information can be displayed in six languages ³⁾

¹⁾ Included on pumps with solenoid valves. Can be factory installed on pumps with manual valve.

²⁾ When used with optional pressure transducer.

³⁾ English, French, German, Italian, Spanish and Portuguese.



Level/Temperature Switch ⁴⁾

- Shuts down pump before oil level reaches an unsafe level, avoiding damage due to cavitation
- Shuts down pump when unsafe oil temperature is reached
- Ideal if pump is used in remote area without visual access to oil level.

⁴⁾ 24 V, requires Electric Box. Available for 10, 20 and 40 litres reservoirs.

Accessory Kit Modelnr.	Fixed Temperature Signal (°C)	Operating Temperature (°C)	Max. Pressure (bar)
ZLS-U4 *	80	5 - 110	10

* Add suffix **L** for factory installation.



Return Line Filter

- 25 micron nominal filter removes contaminants from return oil flow before allowing it back into tank
- Internal by-pass valve prevents damage if filter is dirty
- With maintenance indicator
- Replaceable filter element PF25.

Accessory Kit Modelnr.	Maximum Pressure (bar)	Maximum Oil Flow (l/min)	By-pass Setting (bar)
ZPF *	13,8	45,4	1,7

* Add suffix **F** for factory installation.



Roll Cage

- For easy portability and hoisting
- Protects pump and electric box
- Available for all reservoir sizes.



Skid Bar

- Provides easy two-hand lift
- Provides greater pump stability on soft or uneven surfaces.



Foot Switch ⁵⁾

- Hands-free remote control on solenoid dump and 3-position valves
- With 3 meters cord.

⁵⁾ 15 V, requires Electric Box.

Accessory Kit Nr.	Fits on reservoir size:	 (kg)
ZRC-04 *	4 and 8 litres ⁵⁾	5,5
ZRC-04H *	4 and 8 litres ⁶⁾	6,5
ZRB-10 *	10 litres	6,0
ZRB-20 *	20 litres	6,0
ZRB-40 *	40 litres	6,0

* Add suffix **R** for factory installation.

⁵⁾ For pump without heat exchanger

⁶⁾ For pump with heat exchanger.

Accessory Kit Nr.	Fits on reservoir size:	 (kg)
SBZ-4 *	4 and 8 litres ⁵⁾	2,2
SBZ-4L *	4 and 8 litres ⁶⁾	3,2

* Add suffix **K** for factory installation.

Accessory Kit Nr.	Can be used on ZE-Series pumps with
ZCF-2 *	Solenoid VE-Series valves

* Add suffix **U** for factory installation.

ZE-Series, Options & Accessories



Pressure Transducer ¹⁾

- Displays pressure on LCD in bar, MPa or psi
- More accurate than analog gauge
- Calibration can be fine-tuned for certification
- Easy-viewing variable rate display
- “Set pressure” feature turns off motor at user defined pressure ²⁾.

¹⁾ 24 V, requires Electric Box.

²⁾ Or shifts valve to neutral position on pump models with VE33 and VE43 solenoid valves.

Accessory Kit Modelnr.	Adjustable Pressure Range (bar)	Switch-point repeatability	Dead-band (bar)
ZPT-U4 *	3,5 - 700	± 0,5%	3,5

* Add suffix **T** for factory installation.



Pressure Switch ³⁾

- Controls pump, monitors system
- Adjustable pressure 35-700 bar
- Includes glycerine filled 1000 bar pressure gauge G2536L
- Accuracy ± 1,5% of full scale.

³⁾ 24 V, requires Electric Box. Not available in combination with pressure transducer. Not available on LCD-electronics.

Accessory Kit Modelnr.	Switch-point repeatability	Deadband (bar)	Oil Ports (NPTF)
ZPS-E3 *	± 2%	8 - 38	3/8"

* Add suffix **P** for factory installation.



Options

Accessory Kits can be installed by customer. See chart below for options on **Standard Electric** (without electric box) or **LCD Electric** (with electric box). Refer to page 103 for ordering matrix.

ZE-Series Options	Factory Installed		Accessory Kits	
	Std. Electr.	LCD Electr.	Std. Electr.	LCD Electr.
Return Line Filter	F	F	ZPF	ZPF
Skid Bar ¹⁾	K	K	SBZ	SBZ
Roll Cage	R	R	ZRB	ZRB
Single-stage	S	S	-	-
Heat Exchanger	-	H	-	ZHE
Pressure Gauge ²⁾	G	G	-	-
Pressure Switch ³⁾	-	P	-	ZPS-E3
Pressure Transducer ⁴⁾	-	T	-	ZPT-U4
Level/Temp Switch ⁵⁾	-	L	-	ZLS-U4
Foot Switch ⁶⁾	-	U	-	ZCF-2

¹⁾ Available for 4 and 8 litres reservoirs.

²⁾ Not available on pumps with pressure transducer.

³⁾ Includes 1000 bar gauge. Only available on manual valves without locking feature.

⁴⁾ Electric box can accept either pressure switch or pressure transducer, but not both.

⁵⁾ Available for 10, 20 and 40 litres reservoirs.

⁶⁾ For control of solenoid dump and 3-position valves.



Pendants ⁴⁾

- For pump types with valve operation “W” (No Valve, with Electric Box, without pendant).

⁴⁾ When ordering Enerpac VE-Series solenoid valve the pendant must be ordered separately. Pendant connection to be plugged into electric box.

Pendant Model Nr.	To be used with solenoid valve:
ZCP-1	VE32D
ZCP-3	VE32, VE33, VE43



Heat Exchanger ⁵⁾

- Removes heat from by-pass oil to provide cooler operation
- Stabilizes oil viscosity, increasing oil life and reduces wear of pump and other hydraulic components.

Accessory Kit Nr.	Fits on reservoir size:	(kg)
ZHE-E04 *	4 and 8 litres	4,1
ZHE-E10 *	10, 20 and 40 litres	4,1

⁵⁾ 24 VDC, requires electric box.

* Add suffix **H** for factory installation.



ZPT-U4 Pressure Transducer

More durable against mechanical and hydraulic shock than analog gauges.

- Digital pressure read-out provides accuracy of 0,5% of full scale.
- Easy-viewing variable rate display automatically varies increments between 3, 14, 35 and 145 bar as rate of pressure change increases.
- “Set pressure” feature turns off motor at user defined pressure (or shifts valve to neutral on VE33 and VE43 valves).



ZHE-Series Heat Exchangers

Heat exchanger stabilizes oil temperature at 54 °C at 21 °C ambient temperature. Thermal transfer at 1,9 l/min and 21 °C ambient temperature: 900 Btu/hour [950 kJ].

Do not exceed max. oil flow of 26,5 l/min and max. pressure of 20,7 bar. Not suitable for water-glycol or high water based fluids.

ZE-Series, Specifications & Dimensions

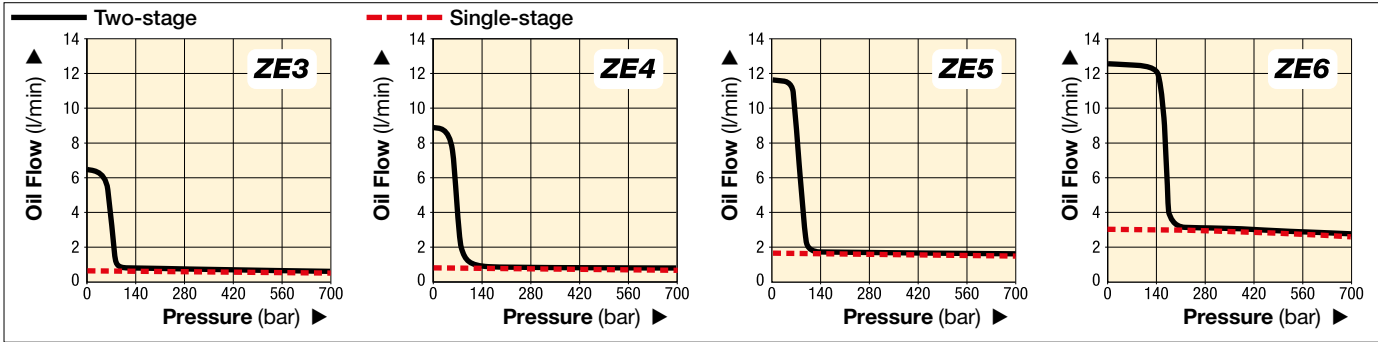

▼ ZE-SERIES PERFORMANCE CHART

Pump Series	Output Flow Rate at 50 Hz * (l/min)				Pump Unit	Available Reservoir Sizes (useable oil) (litres)	Motor Size (kW)	Relief Valve Adjustment Range (bar)	Sound Level (dBA)
	low pressure at 7 bar	low pressure at 50 bar	high pressure at 350 bar	high pressure at 700 bar					
ZE3	0,59	0,59	0,57	0,55	Single-stage	4-8-10-20-40	0,75	70-700	75
	6,15	5,26	0,57	0,55	Two-stage				
ZE4	0,87	0,87	0,84	0,82	Single-stage	4-8-10-20-40	1,12	70-700	75
	8,88	8,20	0,84	0,82	Two-stage				
ZE5	1,75	1,72	1,68	1,64	Single-stage	10-20-40	2,24	70-700	75
	11,61	11,27	1,68	1,64	Two-stage				
ZE6	3,00	2,94	2,86	2,73	Single-stage	10-20-40	5,60	70-700	80
	12,29	12,15	2,86	2,73	Two-stage				

* Oil flow will be approximately 6/5 of these values at 60 Hz.



Single or Two-Stage

Choose single-stage pumps for applications that require constant flow regardless of pressure such as testing or clamping. Two-stage pumps have an increased output flow at low pressure to allow fast movement towards the load, for reduced cycle times and increased productivity.

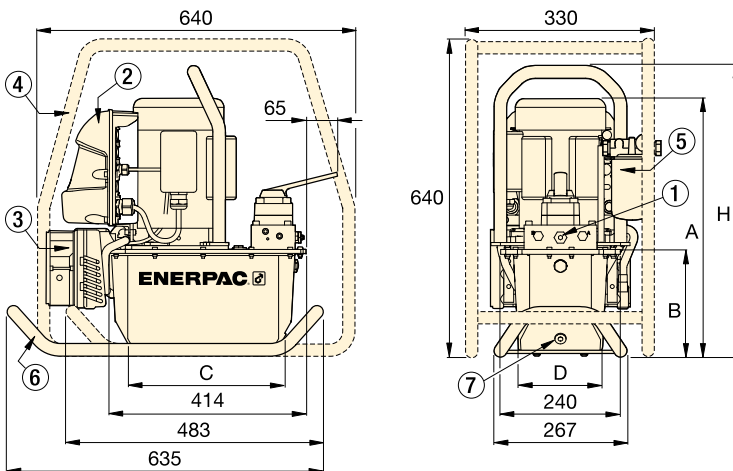

ZE-Series Pumps with 4 - 8 litres reservoir

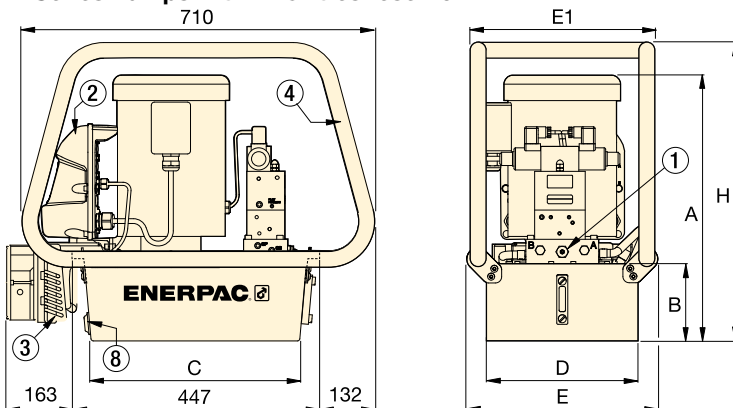

ZE-Series Pumps with 10 - 20 - 40 litres reservoir

- ① User adjustable relief valve on all manual and solenoid valves.
3/8" NPTF on A and B ports;
1/4" NPTF on auxiliary ports.
- ② Electric Box
- ③ Heat Exchanger
- ④ Roll Cage
- ⑤ Return Line Filter
- ⑥ Skid Bar
- ⑦ Magnetic Oil Drain
- ⑧ Oil Drain / Oil Level/Temperature Switch

Reservoir Size (useable oil in litres)	ZE-Series Pump Dimensions (mm)						
	A	B	C	D	E	E1	H
4,0	457	143	279	152	-	-	513
8,0	457	143	279	206	-	-	513
10,0	533	158	419	305	384	371	600
20,0	558	180	419	422	501	488	625
40,0	648	270	399	505	576	572	715

ZE-Series, Pump Ordering Matrix

▼ This is how ZE-Series pump model numbers are built up:

Z	E	4	1	10	D	W	-	F	H	L	T
1	2	3	4	5	6	7		8			
Product Type	Motor Type	Flow Group	Valve Type	Reservoir Size	Valve Operation	Motor Voltage		Options and Accessories			

1 Product Type

Z = Pump Class

2 Prime Mover

E = Induction electric motor

3 Flow Group

- 3** = 0,55 l/min @ 700 bar (0,75 kW)
- 4** = 0,82 l/min @ 700 bar (1,12 kW)
- 5¹⁾** = 1,64 l/min @ 700 bar (2,24 kW)
- 6¹⁾** = 2,73 l/min @ 700 bar (5,60 kW)

4 Valve Type

- 0** = No valve, with cover plate
- 1** = 3/2 Dump valve **VE32D**
- 2** = 3/2 manual **VM32**
- 3** = 3/3 manual **VM33** or electric **VE33**
- 4** = 4/3 manual **VM43** or electric **VE43**
- 6** = 3/3 manual locking valve **VM33L** with pilot operated check.
- 8** = 4/3 manual locking valve **VM43L** with pilot operated check.
- 9** = 4 way/3 position manual with power seating (**VM43-LPS**)
- 10** = 3 way/3 position manual **Venturi** valve (**VM33VAC**)
- 11** = 4 way/3 position electric **Venturi** valve (**VE33VAC**)
- 12** = 3 way/3 position manual locking **Venturi** valve (**VM33LVAC**)

8 Options and Accessories

- F** = Return Line Filter
- G⁶⁾** = 1000 bar gauge
- H⁷⁾** = Heat exchanger
- K** = Skid Bar (only on 4 and 8 litres)
- L⁷⁾** = Oil Level/Temperature Switch⁸⁾
- N** = No reservoir handles (includes lifting eyes)

5 Reservoir Size, useable oil

- 04²⁾** = 4 litres
- 08²⁾** = 8 litres
- 10** = 10 litres
- 20** = 20 litres
- 40** = 40 litres

6 Valve Operation

- D** = Dump valve (solenoid), with pendant and Electric Box (LCD)
- L** = Manual valve, without pendant, with Electr. Box (LCD)
- M** = Manual valve, without pendant, without Electric Box
- N** = No valve, without Electric Box
- S** = Solenoid valve, with pendant and Electric Box (LCD)
- W** = No valve, with Electric Box (LCD), without pendant¹⁰⁾

7 Motor Voltage

Single phase motor³⁾

- B³⁾** = 115V, 1 ph, 50-60Hz
- E³⁾** = 208-240V, 1 ph, 50-60 Hz⁴⁾
- I** = 208-240V, 1 ph, 50-60 Hz USA plug

Three phase motor⁵⁾

- M⁵⁾** = 190-200V, 3 ph, 50-60Hz
- G⁵⁾** = 208-240V, 3 ph, 50-60 Hz
- W⁵⁾** = 380-415V, 3 ph, 50-60 Hz
- K⁵⁾** = 440V, 3 ph, 50-60 Hz
- J⁵⁾** = 460-480V, 3 ph, 50-60 Hz
- R⁵⁾** = 575V, 3 ph, 60 Hz

- P⁷⁾** = Pressure Switch (only available on manual valves without locking feature)
- R** = Roll Cage
- S** = Single-stage pump unit
- T⁷⁾** = Pressure transducer⁹⁾
- U⁷⁾** = Foot Switch

¹⁾ ZE5 and ZE6-Series only available with 3-phase electric motors.
²⁾ 4 and 8 litres only available on ZE3 and ZE4-Series.
³⁾ 1-phase motors only available on ZE3 and ZE4-Series
⁴⁾ 208-240V, 1 ph with European plug EMC directive compliant.
⁵⁾ Models with 3-ph motors without Electric Box shipped without cord, motor starter or overload protection.
⁶⁾ Not available on pumps with pressure transducer (T).
⁷⁾ Requires Electric Box.
⁸⁾ Not available on 4 and 8 litres reservoir.
⁹⁾ Provides digital pressure read-out on LCD-display of electric box.
¹⁰⁾ When using solenoid valve on valve type "W" order optional pendant.

All Z-Class electric pumps comply with TÜV and CE requirements.



ZE Series



Reservoir Capacity:

4 - 40 litres

Flow at Rated Pressure:

0,55 - 2,73 l/min

Motor Size:

0,75 - 5,60 kW

Maximum Operating Pressure:

700 bar



How to Order Single-Stage Pumps

To specify a single-stage pump, place the letter "S" at the end of the model number. For example:

ZE4210ME-S

ZE4-Series pump, oil flow 0,82 l/min at 700 bar, VM32 manual valve, 10 litres reservoir, without electrical box, without pendant, 240 Volt 1-phase electric motor and single-stage pump unit.



Assisted Return Pumps

To improve productivity and plunger retraction, Enerpac offers valve configurations designed to accelerate your cylinder retraction speeds, ZU4 and ZE-Series pumps feature **Venturi Valve Technology** to facilitate the faster return of single-acting gravity and spring return cylinders. See valve type in ordering matrix and details in section Directional Control Valves.

PA-Series, Air Hydraulic Foot Pumps

▼ Shown: PA-1150, PA-133



PA Series

Reservoir Capacity:
0,6 - 1,3 litres

Flow at Rated Pressure:
0,13 l/min

Air Consumption:
255 l/min

Maximum Operating Pressure:
700 bar



Reservoir Conversion Kit

Double the reservoir capacity of your existing PA-133 with this easy to install conversion kit.

Model Number

PC-66

- Rugged construction – built for long life and easy service
- Swivel coupling simplifies hydraulic connection and pump operation
- Three-position treadle provides cylinder advance, hold or retract operation
- Operates in all positions for increased versatility in use and mounting (except PA-1150)
- Base mounting slots provided on PA-133.

OIL FLOW VERSUS PRESSURE

at 6,9 bar air pressure

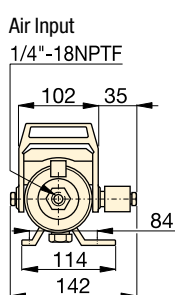
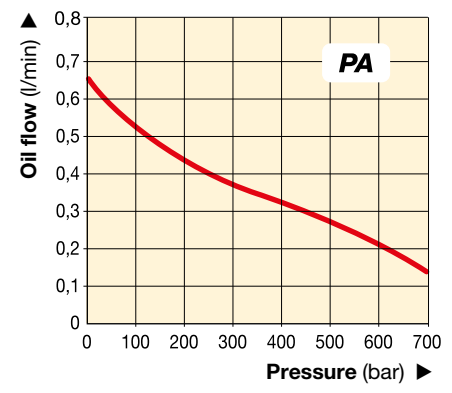

PA-133

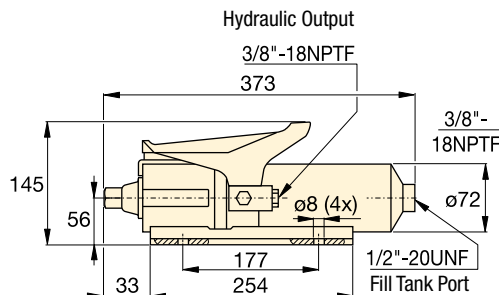

PA-1150

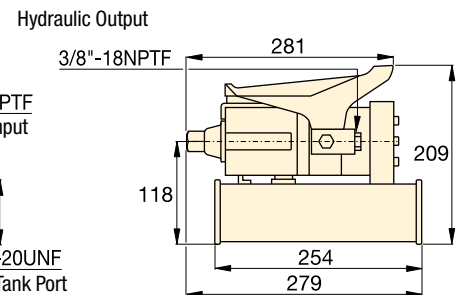
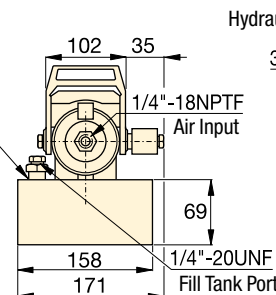

Used with Cylinder	Usable Oil Capacity (cm ³)	Model Number	Pressure Rating (bar)	Output Flow Rate (l/min)		Valve Function	Air Pressure Range* (bar)	Air Consumption (l/min)	Sound Level (dBA)	Weight (kg)
				No load	Load					
Single-Acting	589	PA-133	700	0,65	0,13	Advance / Hold / Retract	4,1 - 8,3	255	85	5,4
	1311	PA-1150	700	0,65	0,13	Advance / Hold / Retract	4,1 - 8,3	255	85	8,2

* Recommended Regulator-Filter-Lubricator: RFL-102.

PAM-Series, Air Hydraulic Pumps

▼ Shown: PAM-1041



PAM Series

Reservoir Capacity:
4,0 - 8,0 litres

Flow at Rated Pressure:
0,15 l/min

Air Consumption:
510 l/min

Maximum Operating Pressure:
700 bar



Locking Valves

Pumps with 4/3 manual valves are available with 4/3 manual locking valves instead. Add suffix "L" to pump model number.

Page: 116



Remote Air Valve

For remote operation of PAM-Series air pumps. Permits either hand or foot operation.

Model Number

VA-2

- Twin air motor configuration delivers high-flow performance in first stage, up to 14 bar, for rapid cylinder advance
- 4 and 8 litres reservoirs for use with a wide range of cylinders
- Integral shroud protects air motors and provides easy portability.

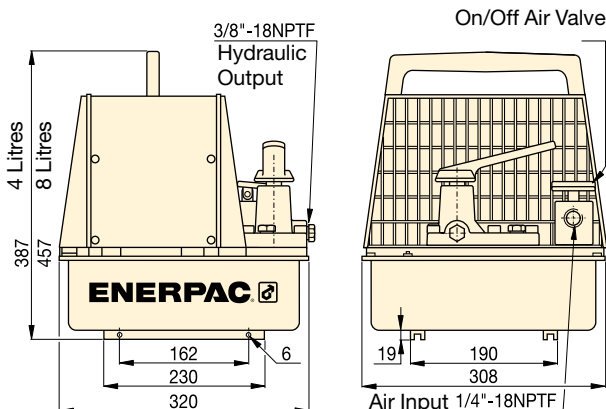

OIL FLOW VERSUS PRESSURE

at 6,9 bar air pressure

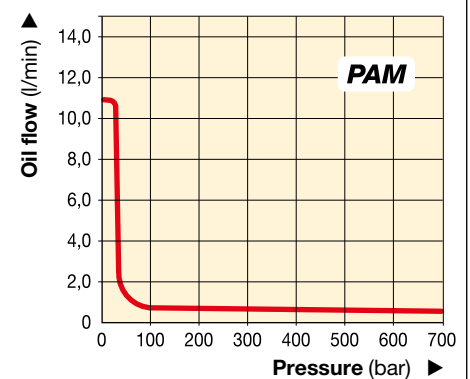

Used with Cylinder	Usable Oil Cap. (litres)	Model Number with Shroud	Pressure Rating (bar)	Output Flow Rate (l/min)		Valve Function	Valve Type	Air Pressure Range * (bar)	Air Consumption (l/min)	Sound Level (dBA)	Weight (kg)
				1 st stage	2 nd stage						
Single-Acting	2,6	PAM-1021	700	10,65	0,15	Advance / Hold / Retract	3/2	4,1 - 8,3	510	87	22,7
	7,6	PAM-1022	700	10,65	0,15	Advance / Hold / Retract	3/2	4,1 - 8,3	510	87	27,2
Double-Acting	2,6	PAM-1041	700	10,65	0,15	Advance / Hold / Retract	4/3	4,1 - 8,3	510	87	22,7
	7,6	PAM-1042	700	10,65	0,15	Advance / Hold / Retract	4/3	4,1 - 8,3	510	87	27,2

* Recommended Regulator-Filter-Lubricator: RFL-102.

▼ Shown from top to bottom: PAMG-1402N, PARG-1102N, PATG-1102N, PATG-1105N



- External adjustable pressure relief valve (behind sight glass)
- Return-to-tank port for use in remote valve applications
- Internal pressure relief valve provides overload protection
- Quieter operation – reduced noise level to 76 dBA
- Operating air pressure: 2,8 - 8,8 bar, enables pump to start at extremely low pressure
- High efficiency cast aluminium air motor
- Reinforced heavy-duty lightweight reservoir for applications in tough environments
- Air pendant for remote control operation.

Compact Air Over Hydraulic



Regulator-Filter-Lubricator

Recommended for use with all Turbo air pumps. Provides clean, lubricated air and allows for air pressure adjustment. Steel bowl guards are standard.

Model Number

RFL-102



Large Reservoir Models

The Turbo II Air Pump is also available with an enlarged reservoir: **PATG-1105N**, **PAMG-1405N** and **PARG-1105N**.



Hoses

Enerpac offers a complete line of high quality hydraulic hoses. To ensure the integrity of your system, specify only genuine Enerpac hydraulic hoses.

Page: **122**

▼ Easily operated by hand or by foot.



Used with Cylinder	Usable Oil Capacity (cm ³)	Model Number
Single-Acting	2081	PATG-1102N
	3770	PATG-1105N
Single-Acting	2081	PARG-1102N
	3770	PARG-1105N
Double-Acting	2081	PAMG-1402N
	3770	PAMG-1405N

PA-Series, Turbo II Air Hydraulic Pumps



PATG-models use a foot or hand operated treadle to control air and valve functions.

PAMG-models use a treadle with a locking feature to control air, and a 4-way manual valve to control hydraulics.

PARG-models use air pendant for remote control.

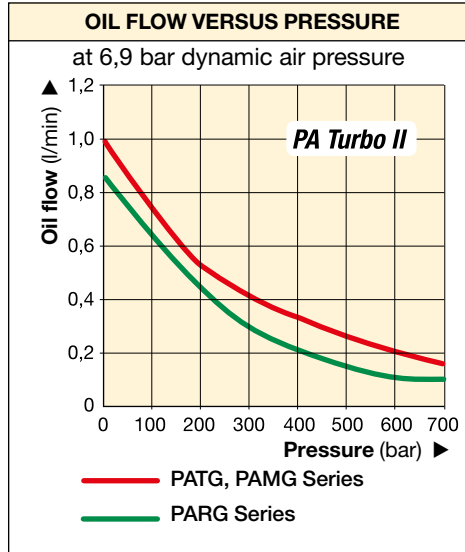

**PATG
PAMG
PARG
Series**



Reservoir Capacity:
2,5 - 5,0 litres

Flow at Rated Pressure:
0,10 - 0,16 l/min

Air Consumption:
227 - 340 l/min

Maximum Operating Pressure:
700 bar

Maximum Pressure (bar)	Output Flow Rate (l/min)		Pump Series	Valve Function	Air Pressure Range (bar)	Air Consumption at 5,2 bar air (l/min)	Sound Level (dBA)
	No Load	Load					
700	1,00	0,16	PATG	A / H / R *	2,8 - 8,8	340	76
700	0,76	0,10	PARG	A / H / R *	2,8 - 10,3	227	76
700	1,00	0,16	PAMG	A / H / R *	2,8 - 8,8	340	76

* Valve function: Advance / Hold / Retract.



Speed Chart

To determine how a specific pump will operate your cylinder, see the Pump-Cylinder Speed Chart in the 'Yellow Pages'.

Page: 273

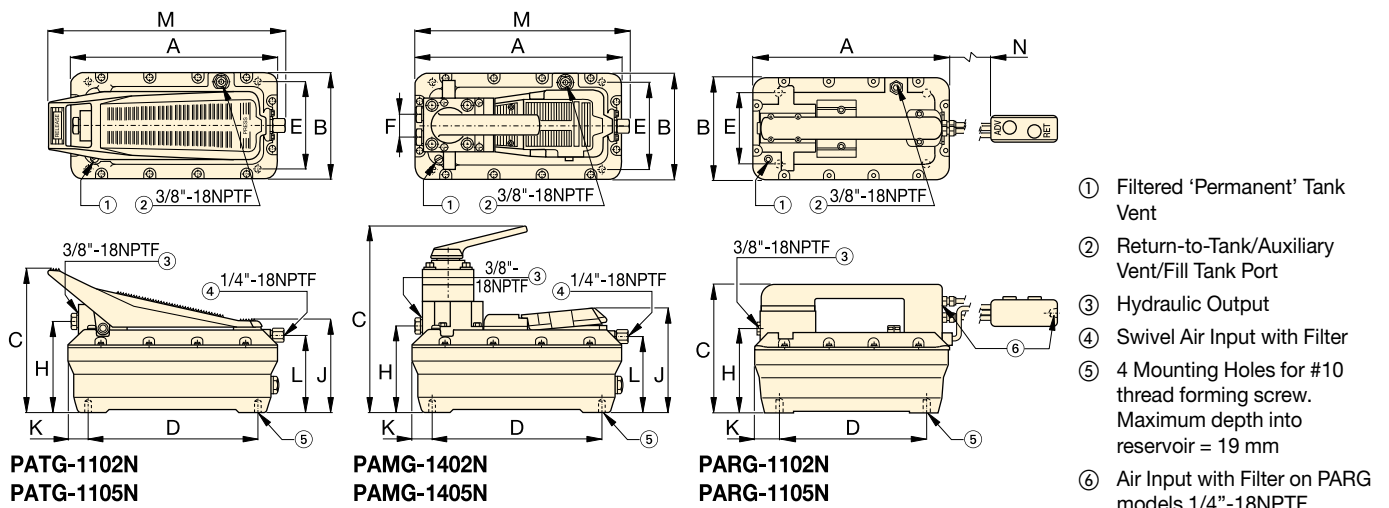

**PATG-1102N
PATG-1105N**

**PAMG-1402N
PAMG-1405N**

**PARG-1102N
PARG-1105N**

Valve Operation	Turbo II Dimensions (mm)													Model Number
	A	B	C	D	E	F	H	J	K	L	M	N	(kg)	
Treadle 3/3	313	165	211	230	102	-	129	146	42	113	347	-	8,2	PATG-1102N
	396	201	209	230	102	-	131	146	86	112	437	-	9,9	PATG-1105N
Air Pendant 3/3	313	165	200	230	102	-	129	-	42	-	-	4500	10,0	PARG-1102N
	396	201	209	230	102	-	131	-	86	-	-	4500	11,7	PARG-1105N
Manual 4/3	313	165	267	230	102	36	130	152	42	113	315	-	11,0	PAMG-1402N
	396	201	267	230	102	36	132	152	86	112	405	-	12,7	PAMG-1405N

▼ Shown: XA11G



- Ergonomic design for less operator fatigue
- Variable oil flow & fine metering for precise control
- Higher oil flow for increased productivity
- Closed hydraulic system prevents contamination and allows pump usage in any position
- Pedal lock function for retract position
- External adjustable pressure setting valve
- Ground screw for improved ATEX explosion safety.

 II 2 GD ck T4

▼ Easy operated by foot. No need to fully lift up foot – rest bodyweight on heel, resulting in a handsfree and stabile working position.



Productivity & Ergonomics



Optional Pressure Gauge

Integrated gauge with calibrated scale reading in bar, psi and MPa for actual pressure reading.



4/3 Control Valve

For powering double-acting hydraulic cylinders and tools.



2 Litres Reservoir

Double oil capacity for powering larger hydraulic cylinders and tools.



Pedal Safety Guard

Customer installed frame protects both pedals against accidental activation.

Model Number¹⁾

XPG1



"Joy-stick" Lever Kit

Customer installed set of handles for manual operation of both pedals.

Model Number¹⁾

XLK1



Swivel Connector

Customer installed swivel connector for optimal orientation of the hydraulic hose. See page 127 for details.

Model Number¹⁾

XSC1

¹⁾ Accessories must be ordered separately.

Air Driven Hydraulic Foot Pumps



Production Application

XA11 pump is used with a 13 tons hollow cylinder to compress and position diesel engine valve springs.

The operator benefits from the fine metering capacities of this pump to apply the mandatory precise stroke and force.

XA Series



Reservoir Capacity:

1,0 - 2,0 litres

Flow at Rated Pressure:

0,25 l/min

Air Consumption:

283 - 991 l/min

Maximum Operating Pressure:

700 bar

▼ XA-SERIES PERFORMANCE CHART

Maximum Pressure (bar)	Output Flow Rate (l/min)		Pump Series	Valve Function	Dynamic Air Pressure (bar)
	No load	Load			
700	2,0	0,25	XA1	Advance / Hold / Retract	2,1 - 8,6

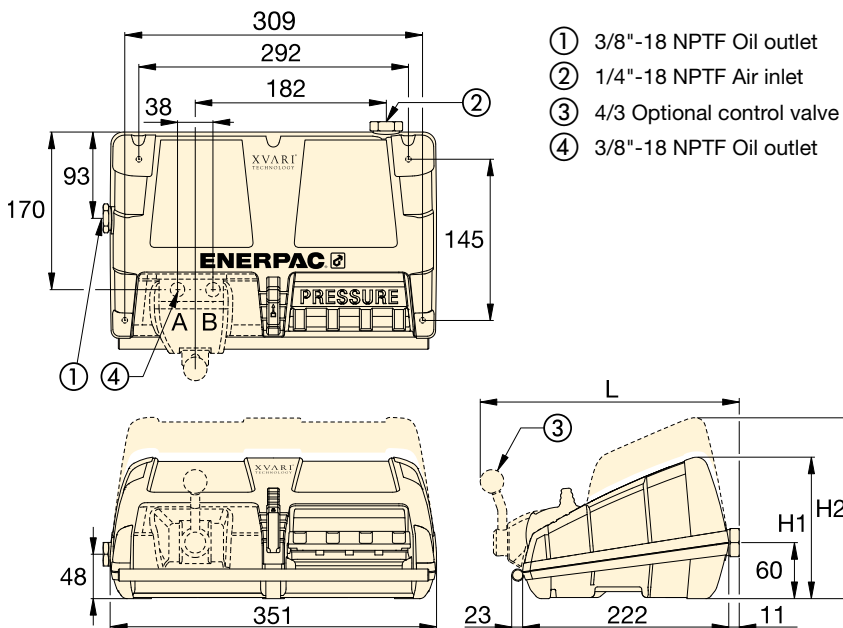

OIL FLOW VERSUS PRESSURE

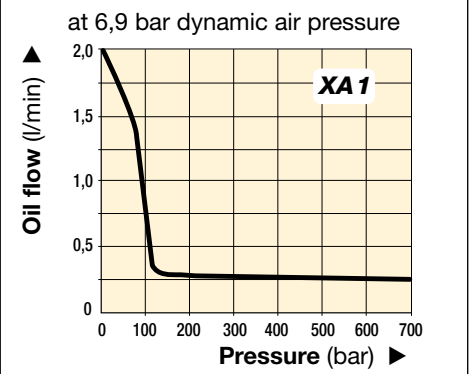

Regulator-Filter-Lubricator

Recommended for use with all XA-Series Air pumps. Provides clean, lubricated air and allows for air pressure adjustment.

Model Number ¹⁾

RFL-102

▼ SELECTION CHART

For use with cylinder or tool	Usable Oil Capacity (litres)	Model Number ¹⁾	Pressure Gauge	3-way 3-pos. Valve	4-way 3-pos. Valve	Dimensions (mm)			 (kg)
						H1	H2	L	
Single-acting	1,0	XA 11 ²⁾	–	•	–	152	–	–	8,6
	2,0	XA 12 ²⁾	–	•	–	–	170	–	10,2
Single-acting	1,0	XA 11G	•	•	–	152	–	–	8,8
	2,0	XA 12G	•	•	–	–	170	–	10,4
Double-acting	1,0	XA 11V	–	–	•	152	–	279	10,1
	2,0	XA 12V	–	–	•	–	170	279	11,7
Double-acting	1,0	XA 11VG	•	–	•	152	–	279	10,3
	2,0	XA 12VG	•	–	•	–	170	279	11,9

¹⁾ High-Flow coupler CR-400 and accessories must be ordered separately. ²⁾ Available as cylinder-pump set, see page 58.

▼ Shown: ZA4208MX, ZA4420MX



Z Tough Dependable Innovative CLASS



ATEX 95 Certified

The Enerpac ZA4-series air pumps are tested and certified according to the **Equipment Directive 94 / 9 / EC "ATEX Directive"** for equipment and protective systems intended for use in potentially explosive atmospheres.



Page: 263

- ATEX 95 certified for use in potentially explosive atmospheres
- Features Z-Class high efficiency pump design, higher oil flow and bypass pressure
- Two-speed operation reduces cycle time for improved productivity
- User adjustable relief valve built-in on manual valves. Oil ports on valves are 3/8" NPTF
- Optional heat exchanger warms exhaust air to prevent freezing and cools the oil
- Full sight oil level glass on 10, 20 and 40 litres reservoirs, oil level indicators on 4 and 6,6 litres reservoirs.



Speed Chart

To determine how a specific pump will operate your cylinder, see the Pump-Cylinder Speed Chart in the 'Yellow Pages'.

Page: 273



Hoses

Enerpac offers a complete line of high quality hydraulic hoses. To ensure the integrity of your system, specify only genuine Enerpac hydraulic hoses.

Page: 122

Used with Cylinder	Usable Oil Capacity (litres)	Manual Valve ¹⁾ Model Number	Valve Function	Model Number	Output Flow Rate ²⁾				Relief Valve Adjustment Range (bar)	Maximum Air Consumption ³⁾ (l/min)
					at 7 bar	at 50 bar	at 350 bar	at 700 bar		
–	4,0	–	–	ZA4004NX	14,0	11,0	1,8	1,3	–	2840
Single-acting	4,0	VM32	Advance / Retract	ZA4204MX	14,0	11,0	1,8	1,3	70 - 700	2840
	6,6	VM33	Advance / Hold /Retract	ZA4308MX	14,0	11,0	1,8	1,3	70 - 700	2840
	10,0	VM33L	Advance / Hold /Retract	ZA4610MX	14,0	11,0	1,8	1,3	70 - 700	2840
Double-acting	4,0	VM43	Advance / Hold /Retract	ZA4404MX	14,0	11,0	1,8	1,3	70 - 700	2840
	6,6	VM43	Advance / Hold /Retract	ZA4408MX	14,0	11,0	1,8	1,3	70 - 700	2840
	10,0	VM43L	Advance / Hold /Retract	ZA4810MX	14,0	11,0	1,8	1,3	70 - 700	2840
	20,0	VM43	Advance / Hold /Retract	ZA4420MX	14,0	11,0	1,8	1,3	70 - 700	2840
	40,0	VM43	Advance / Hold /Retract	ZA4440MX	14,0	11,0	1,8	1,3	70 - 700	2840

¹⁾ See pages 116-117 for hydraulic symbols of these valves.

²⁾ Actual oil flow will vary with air supply.

³⁾ Dynamic air pressure range: 4 - 7 bar.

Modulair Air Hydraulic Pumps

▼ This is how a ZA4-Series pump model number is built up:



1 Product Type

Z = Pump Class

2 Prime Mover

A = Air motor

3 Flow Group

4 = 1,3 l/min @ 700 bar

4 Valve Type

- 0** = No valve, with cover plate
- 2** = 3/2 manual valve VM32
- 3** = 3/3 manual valve VM33
- 4** = 4/3 manual valve VM43
- 6** = 3/3 manual locking valve VM33L with pilot operated check
- 7** = 3/2 manual valve VM22
- 8** = 4/3 manual locking valve VM43L with pilot operated check.

5 Reservoir Size, useable oil

- 04** = 4 litres
- 08** = 6,6 litres
- 10** = 10 litres
- 20** = 20 litres
- 40** = 40 litres

6 Valve Operation

- M** = Manual valve
- N** = No valve

7 Motor Voltage

- X** = Not applicable

8 Options

- F** = Return Line Filter
- G** = 1000 bar gauge
- H** = Heat exchanger (on 4 and 6,6 litres reservoir only)
- K** = Skid Bar (on 4 and 6,6 litres reservoir only)
- N** = No reservoir handles (includes lifting eyes on 10, 20 and 40 litres)
- R** = Roll Cage

Ordering Example

Model Number: **ZA4208MX-FHK**
 ZA4208MX-FHK is an air operated pump with a 3-way, 2-position manual valve, 6,6 litres reservoir, filter, heat exchanger and skid bar.

ZA4 Series



Reservoir Capacity:

4 - 40 litres

Flow at Rated Pressure:

1,3 l/min

Air Consumption:

2840 l/min

Maximum Operating Pressure:

700 bar

- ① User adjustable relief valve on all manual valves. 3/8" NPTF on A and B ports; 1/4" NPTF on auxiliary ports.
- ② Air inlet 1/2" NPTF
- ③ Return Line Filter (optional)
- ④ Oil Sight Gauge
- ⑤ Roll Cage (optional)
- ⑥ Oil Drain
- ⑦ Lifting eyes (optional)
- ⑧ Handles
- ⑨ Skid Bar (Modelnr. SBZ-4) (optional)

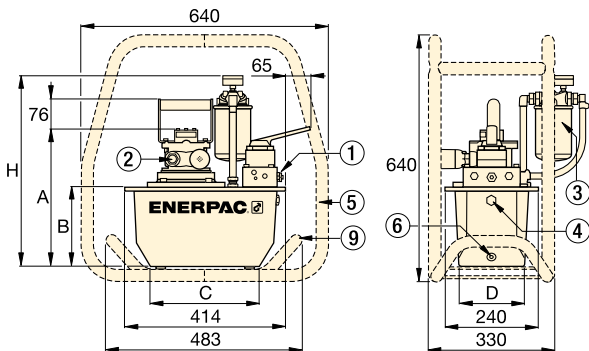

ZA4-Series Pumps with 4 - 6,6 litres reservoir

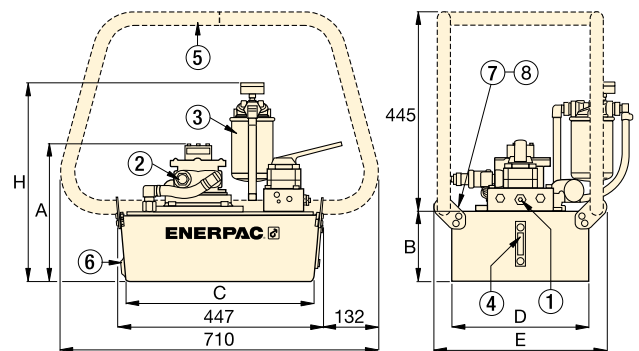

ZA4-Series Pumps with 10, 20 and 40 litres reservoir

Sound Level (dBA)	Motor Size (kW)	Dimensions (mm)							Weight (kg)	Model Number
		A	B	C	D	E	H			
80 - 95	3,0	295	142	279	152	-	429	27	ZA4004NX	
80 - 95	3,0	295	142	279	152	-	429	30	ZA4204MX	
80 - 95	3,0	356	203	279	205	-	490	34	ZA4308MX	
80 - 95	3,0	330	180	414	421	500	467	51	ZA4610MX	
80 - 95	3,0	295	142	279	152	-	429	31	ZA4404MX	
80 - 95	3,0	356	203	279	205	-	490	35	ZA4408MX	
80 - 95	3,0	305	155	419	305	384	442	40	ZA4810MX	
80 - 95	3,0	330	180	414	421	500	467	52	ZA4420MX	
80 - 95	3,0	419	269	399	505	584	556	75	ZA4440MX	

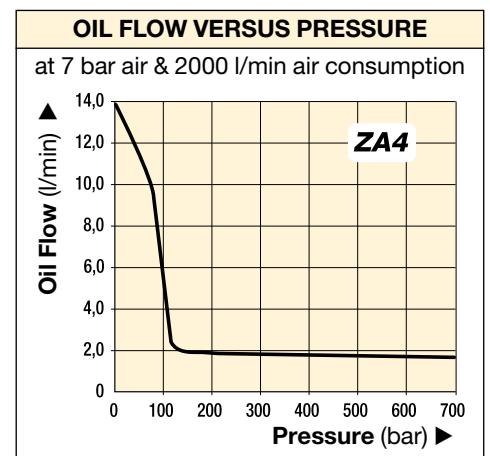

ZG-Series, Gasoline Hydraulic Pumps

▼ Shown from left to right: ZG6440MX-BFCH, ZG5420MX-B



Z Tough,
Dependable,
Innovative
CLASS



Speed Chart

To determine how a specific pump will operate your cylinder, see the Pump-Cylinder Speed Chart in the 'Yellow Pages'.

Page: **273**

- Features Z-Class high efficiency pump design, higher oil flow and bypass pressure
- Two-speed operation reduces cycle time for improved productivity
- User adjustable relief valve built-in on manual valves. Oil ports on valves are 3/8" NPTF
- Available in three 4-cycle engine sizes: 4,1 kW Honda and 4,8 kW and 9,7 kW Briggs & Stratton
- Full sight oil level glass on all reservoirs allow quick and easy oil level monitoring.

ZG6-Series

- Easy serviceable 9,7 kW, 4-cycle gasoline engine with electric start, pressurized oil and 12 Volt charge output for accessories
- Dual forced air heat exchangers stabilizes hydraulic oil temperature
- Sturdy wheeled cart with collapsible handles.



GA45GC Gauge Adaptor Assembly

Protect yourself from system overloading by simply ordering one part number for a pre-assembled gauge, adaptor block and coupler.

Page: **134**



User Adjustable Relief Valve

All VM-Series directional valves have a user adjustable relief valve to allow the operator to easily set the optimum working pressure.

Page: **116**

▼ SELECTION CHART

Used with Cylinder	Usable Oil Capacity (litres)	Manual Valve ¹⁾ Model Number	Valve Function	Model Number with Roll Cage	Output Flow Rate (l/min)				4-Cycle Engine Type and Size
					at 7 bar	at 50 bar	at 350 bar	at 700 bar	
Single-Acting	10	VM33	Advance / Hold / Retract	ZG5310MX-R	11,5	10,7	1,8	1,6	Honda 4,1 kW
	20	VM33	Advance / Hold / Retract	ZG5320MX-R	11,5	10,7	1,8	1,6	
Double-Acting	10	VM43	Advance / Hold / Retract	ZG5410MX-R	11,5	10,7	1,8	1,6	
	20	VM43	Advance / Hold / Retract	ZG5420MX-R	11,5	10,7	1,8	1,6	
Single-Acting	10	VM33	Advance / Hold / Retract	ZG5310MX-BR	6,5	6,2	1,8	1,6	Briggs & Stratton 4,8 kW
	20	VM33	Advance / Hold / Retract	ZG5320MX-BR	6,5	6,2	1,8	1,6	
Double-Acting	10	VM43	Advance / Hold / Retract	ZG5410MX-BR	6,5	6,2	1,8	1,6	
	20	VM43	Advance / Hold / Retract	ZG5420MX-BR	6,5	6,2	1,8	1,6	
	40	VM43L	Advance / Hold / Retract	ZG5840MX-BR	6,5	6,2	1,8	1,6	
Double-Acting	40	VM43	Advance / Hold / Retract	ZG6440MX-BCFH	14,7	14,5	3,7	3,3	
	40	VM43L	Advance / Hold / Retract	ZG6840MX-BCFH	14,7	14,5	3,7	3,3	

¹⁾ See pages 116-117 for hydraulic symbols of these valves.

Gasoline Hydraulic Pumps



ZG-Series, Gasoline Pump Performance

Elevation can affect the performance of any gasoline engine. ZG-Series pumps are designed to develop rated performance at elevations up to 1500 m. For applications above this elevation, please consult your Enerpac office.

Optional: Diesel Engine

ZG-Series pumps can also be equipped with a Diesel Engine. Contact Enerpac for details.

ZG Series



Reservoir Capacity:

10 - 20 - 40 litres

Flow at Rated Pressure:

1,6 - 3,3 l/min

Engine Size:

4,1 - 4,8 - 9,7 kW

Maximum Operating Pressure:

700 bar

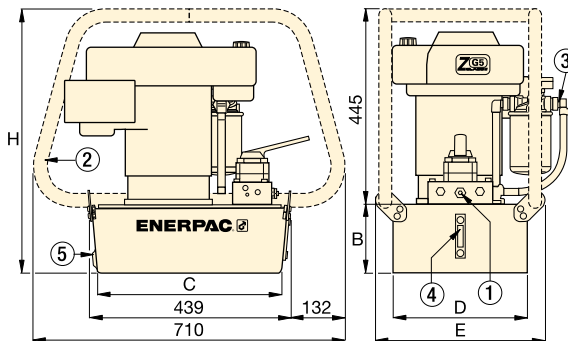

- ① User adjustable relief valve on all manual valves. 3/8" NPTF on A and B ports; 1/4" NPTF on auxiliary ports.
- ② Roll Bar
- ③ Return Line Filter
- ④ Oil Level Gauge
- ⑤ Oil Drain

ZG5-Series

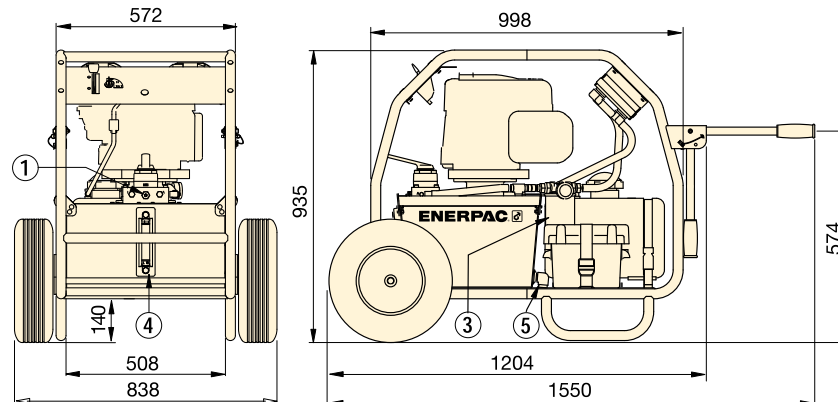

ZG6-Series



High Pressure Hoses

Enerpac offers a complete line of high quality hydraulic hoses. To ensure the integrity of your system, specify only genuine Enerpac hydraulic hoses.

Page: 122



Speed Chart

To determine how a specific pump will operate your cylinder, see the Pump-Cylinder Speed Chart in the 'Yellow Pages'.

Page: 273

Relief Valve Adjustment Range (bar)	Sound Level (dBA)	Dimensions (mm)					Model Number with Roll Cage (kg)	
		B	C	D	E	H		
70 - 700	88 - 93	155	419	305	384	600	52	ZG5310MX-R
		180	414	421	500	625	64	ZG5320MX-R
		155	419	305	384	600	52	ZG5410MX-R
		180	414	421	500	625	64	ZG5420MX-R
70 - 700	88 - 93	155	419	305	384	600	50	ZG5310MX-BR
		180	414	421	500	625	63	ZG5320MX-BR
		155	419	305	384	600	50	ZG5410MX-BR
		180	414	421	500	625	63	ZG5420MX-BR
		269	399	505	557	714	86	ZG5840MX-BR
70 - 700	88 - 93	-	-	-	-	-	152	ZG6440MX-BCFH
		-	-	-	-	-	155	ZG6840MX-BCFH

OIL FLOW VERSUS PRESSURE

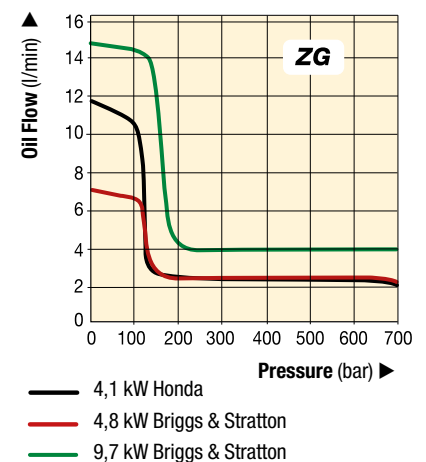

Enerpac hydraulic valves are available in a wide variety of models and configurations.

Whatever your requirements... directional control, flow control, or pressure control... you can be sure that Enerpac has the correct valve to match your application exactly.

Designed and manufactured for safe operation up to 700 bar, the range of Enerpac valves allows for direct pump mounting, remote mounting, manual or solenoid actuation, and in-line installation, giving you flexible solutions to control your hydraulic system.



Assisted Return Pumps

To improve productivity and plunger retraction, Enerpac offers valve configurations designed to accelerate your cylinder retraction speeds.

ZU4 and ZE-Series pumps feature **Venturi Valve Technology** to facilitate the faster return of single-acting gravity and spring return cylinders.



Pressure & Flow Control Valves

For more hydraulic system control with pressure relief valves, shut-off valves, check valves and sequence valves see our "System Components".

Page: 136



Valving Help

See Basic System Set-Up and Valve Information in our 'Yellow Pages'.

Page: 274



Directional Control Valves Section Overview

Valve Type	Series	Page
Pump Mounted Manual and Solenoid Directional Control Valves	VM VE	116 ▶
Remote Mounted Manual Directional Control Valves	VC	118 ▶
Valve Dimensions	VM VE VC	119 ▶

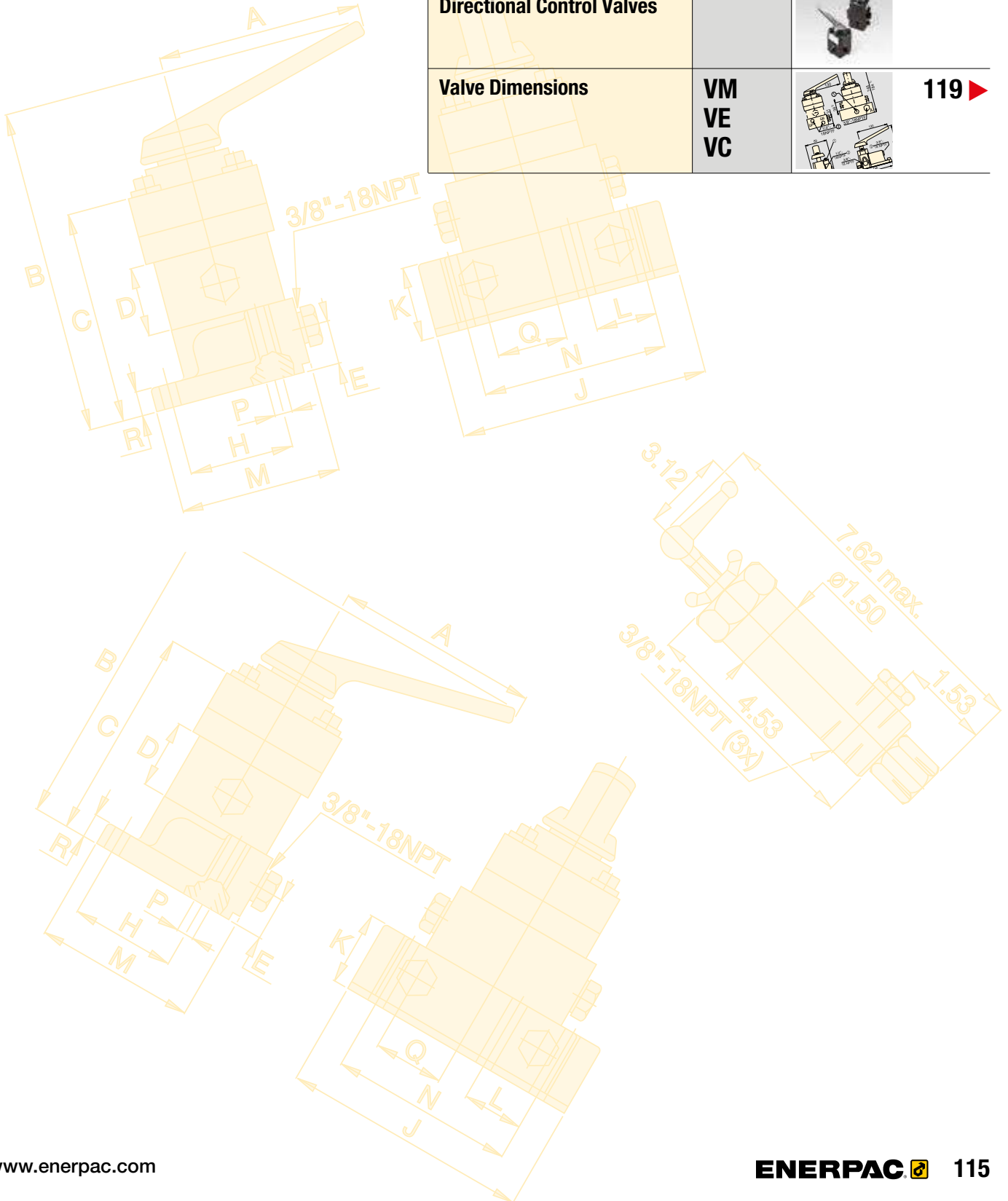

▼ Shown from left to right: VM32, VE33, VM33, VM43L, VE43



- Advance/Retract and Advance/Hold/Retract operation of single- and double-acting cylinders and tools
- Manual or solenoid operation
- Pump mounting will retrofit on most Enerpac pumps
- Available “locking” option on VM-Series valves for load-holding applications
- Standard “locking” feature on VE-Series 3-position valves
- User adjustable relief valve allows the operator to easily set the working pressure.

Venturi Valve Technology

- For fast return of single-acting gravity and spring return cylinders
- Available as manual or solenoid valve on ZU4- and ZE-Series electric pumps
- Retrofit Venturi valve kits for field installation on existing ZU4- and ZE-Series electric pumps.



Adjustable relief valve

All valves feature several gauge ports for “system”, A port and B port pressure monitoring. User adjustable relief valves are included on all models to allow the operator to easily set the optimum working pressure for each application.

VM33 and VE43 valves include “System Check” feature, for more precise pressure holding and improved system control.

The VM33 has improved porting which provides faster cylinder retraction while motor is running.

Locking Valves

For applications that require positive load holding, VM-Series valves (except VM22 and VM32) are available with a pilot-operated check valve. This option provides hydraulic locking of the load until the valve is shifted into the retract position.

Reliable Control of Single and Double-Acting Cylinders and Tools

Valve Operation	Used with Cylinder	Valve Type	
Manual	Single-acting	3-Way, 2-Position	
Manual	Single-acting	3-Way, 2-Position	
Manual	Single-acting	3-Way, 3-Position, Tandem Center	
Manual	Single-acting	3-Way, 3-Position, Tandem Center, Venturi Return Assist	
Manual	Double-acting	4-Way, 3-Position, Tandem Center	
Manual	Single-acting	3-Way, 3-Position, Tandem Center, Locking	
Manual	Double-acting	4-Way, 3-Position, Tandem Center, Locking	
Solenoid 24 VDC	Single-acting	3-Way, 2-Position	
Solenoid 24 VDC	Single-acting	3-Way, 2-Position, Dump	
Solenoid 24 VDC	Single-acting	3-Way, 3-Position, Tandem Center, Venturi Return Assist	
Solenoid 24 VDC	Single-acting	3-Way, 3-Position, Tandem Center	
Solenoid 24 VDC	Double-acting	4-Way, 3-Position, Tandem Center	

For remote valve information, see page 118.
See page 119 for valve dimensions.

Pump Mounted Directional Control Valves

VM VE Series



Maximum Flow Capacity:

17 l/min

Maximum Operating Pressure:

700 bar

Model Number	Hydraulic Symbol	Schematic Flowpath			Weight (kg)
		Advance	Neutral	Retract	
VM22					2,5
VM32					2,5
VM33					3,0
VM33VAC					3,5
VM43					3,1
VM33L					4,8
VM43L					4,9
VE32 ¹⁾					3,9
VE32D ¹⁾					3,9
VE33VAC					10,0
VE33 ¹⁾					9,3
VE43 ¹⁾					9,3

¹⁾ When ordering Enerpac VE-Series solenoid valves, the pendant must be ordered separately for Z-Class. See page 101 for pendant ordering details.



Assisted Return Pumps with Venturi Valve Technology

To improve productivity and plunger retraction, Enerpac offers valve configurations designed to

accelerate your cylinder retraction speeds, ZU4 and ZE-Series pumps feature **Venturi Valve Technology** to facilitate the faster return of single-acting gravity and spring return cylinders.

See valve type in ZU4 and ZE-pump ordering matrix on pages 97 and 103.

Venturi Valve Retrofit Kits

For field installation on existing ZU4, ZE and ZA-Series pumps, Retrofit Kits are available for manual and solenoid operated valves.

For valve model	For valve operation	Retrofit Kit Model Nr.
VM33, VM33L	Manual	VM33RVK
VE33	Solenoid	VUV5



Spring Centred Valve Kits

VM and VC-Series manual 3-position valves can be easily converted into spring centred valves. With these retro-fit kits the

handle will automatically move into the neutral valve position when released.

For valve model	Model Number
VM33, VM43	VMC3343K
VM33L, VM43L	VMC3343KL
VC3, VC15, VC4, VC20	VMC34K
VC3L, VC15L, VC4L, VC20L	VMC34KL

▼ Shown from left to right: VC-20, VC-4L



Remote Control of Single and Double-Acting Cylinders and Tools



Locking Valves

For applications that require positive load holding, VC-Series valves are available with a pilot-operated check valve. This option provides hydraulic locking of the load until the valve is shifted into the retract position.

- Advance/Hold/Retract operation for use with single-acting or double-acting cylinders and tools
- Return line kit included with remote valves.

Valve Operation	Used with Cylinder	Valve Type	Model Number	Hydraulic Symbol	Schematic Flowpath			Weight (kg)
					Advance	Hold	Retract	
Manual	Single-Acting	3-Way, 3-Position, Tandem Center	VC-3					2,9
Manual	Single-Acting	3-Way, 3-Position, Tandem Center, Locking	VC-3L					4,7
Manual	Single-Acting	3-Way, 3-Position, Closed Center	VC-15					2,9
Manual	Single-Acting	3-Way, 3-Position, Closed Center, Locking	VC-15L					4,7
Manual	Double-Acting	4-Way, 3-Position, Tandem Center	VC-4					2,9
Manual	Double-Acting	4-Way, 3-Position, Tandem Center, Locking	VC-4L					4,7
Manual	Double-Acting	4-Way, 3-Position, Closed Center	VC-20					2,9
Manual	Double-Acting	4-Way, 3-Position, Closed Center, Locking	VC-20L					4,7

Directional Control Valves Dimensions

Pump Mounted Directional Control Valves

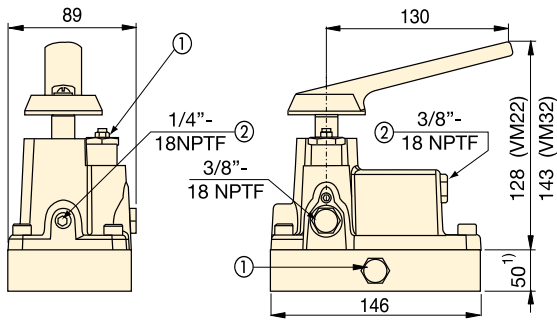

VM22, VM32

¹⁾ VM22 only

- ① User Adjustable Relief Valve
- ② Auxiliary Port

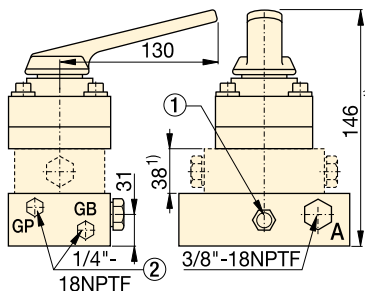

VM33, VM33L, VM33VAC, VM43, VM43L

¹⁾ VM33VAC, VM33L and VM43L only

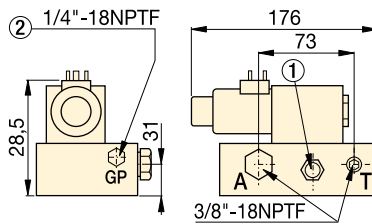

VE32D

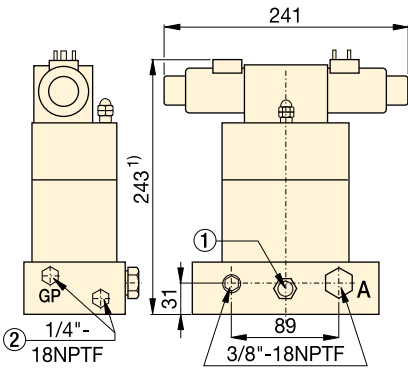

VE33, VE33VAC

¹⁾ VE33VAC is 38 mm higher: 281 mm

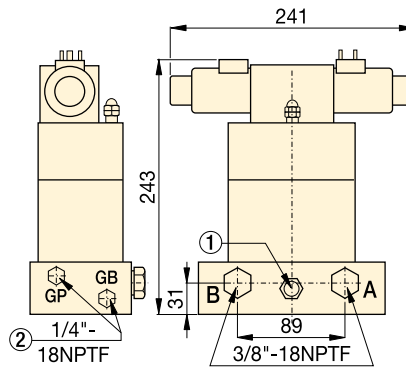

VE43

Remote Manual Directional Control Valves

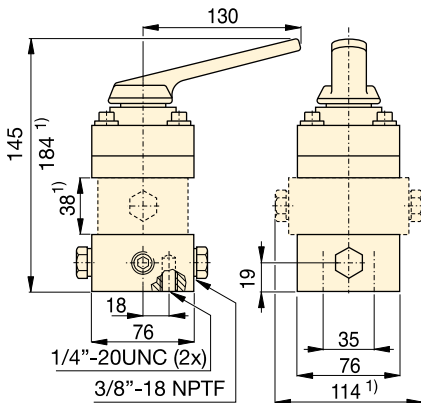

VC-3, VC-3L, VC-15, VC-15L

VC-4, VC-4L, VC-20, VC-20L

¹⁾ VC-3L, VC-15L, VC-4L and VC-20L only

VM VE VC Series



Maximum Flow Capacity:

17 l/min

Maximum Operating Pressure:

700 bar



Spring Centred Valve Kits

VM and VC-Series manual 3-position valves can be easily converted into spring centred valves. With these retro-fit kits the

handle will automatically move into the neutral valve position when released.

For valve model	Model Number
VM33, VM43	VMC3343K
VM33L, VM43L	VMC3343KL
VC3, VC15, VC4, VC20	VMC34K
VC3L, VC15L, VC4L, VC20L	VMC34KL



Gauges

Minimize the risk of overloading and ensure long, dependable service from your equipment. Refer to the System Components

Section for a full range of gauges.

Page: **130**



Fittings

For additional fittings see the fitting page of the System Components section in this catalogue.

Page: **127**



Valving Help

See Basic System Set-Up and Valve Information in our 'Yellow Pages'.

Page: **274**