

The original: made in Germany since 1951



Inventor of
Roller Skates

Moving heavy loads

on Roller Skates Express
and Heavy Duty Wheels

easily and safely
worldwide

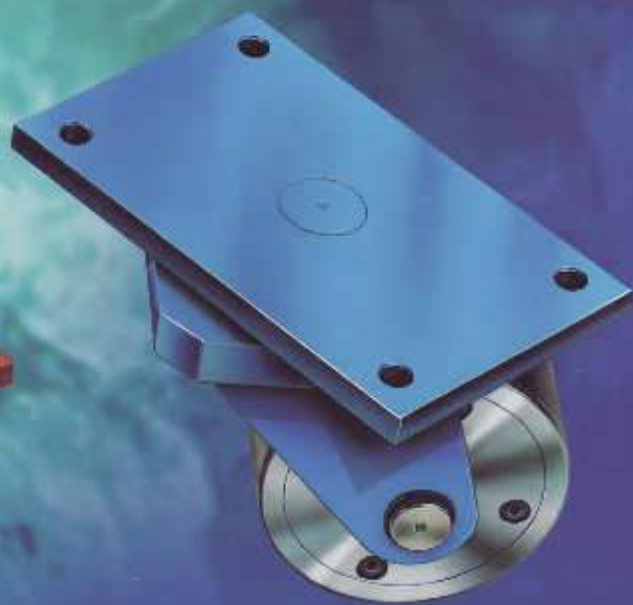
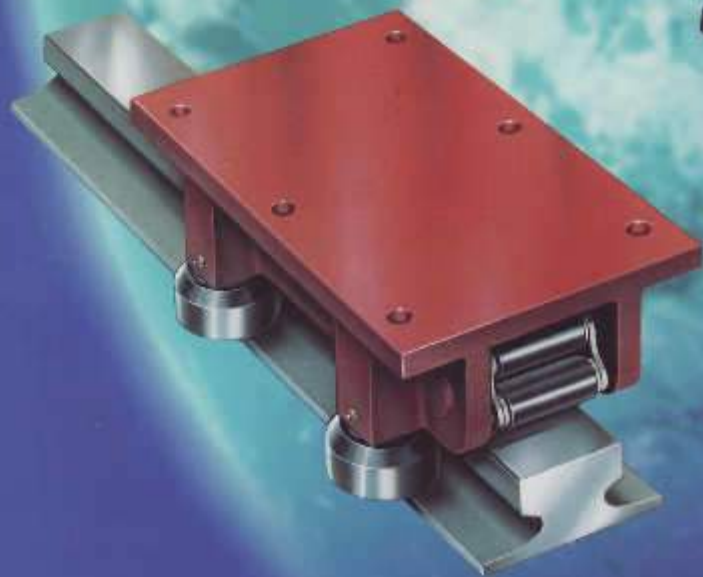
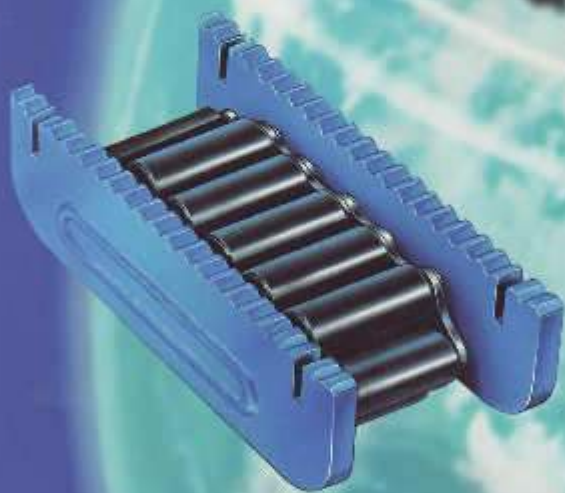

Moving heavy loads easily and safely with ROLLER SKATE EXPRESS – one of the smallest transport devices with the highest carrying capacity available.

The idea

We started with the idea of placing the rear roller automatically in front whilst using 3 rollers or bars to advance the load. This reduces the danger of accidents and ensures easier, continuous transportation. From this idea we developed our industrial skate for moving heavy loads:

Roller Skate Express

Advantages

The advantages of using Roller Skate Express are self-evident:

- solid construction guarantees long product life with minimum maintenance.
- low level construction of Roller Skate (between 7 and 20 cm) reduces the danger of tilting and requires minimum raising of the load whilst placing the Roller Skate underneath.
- little effort required to overcome rolling resistance within the chain assembly (approximately 3 % of total load under ideal conditions and using a larger diameter of roller).
- a variety of applications for very different conditions.
Several decades (more than 50 years) of experience in numerous applications.
 - at sea, (on, under and in the sea, and offshore)
 - on land (bridge-building and relocation of bridges or bridge-parts, moving of complete spectators' stand, of complete blast furnace, of big machinery, parts of nuclear reactors, as a machine-part in tube production machines, in tunnelling (Métro of Paris, Montblanc tunnel, channel Eurotunnel))
- versatile universal transportation device.
- very economic basic unit.

Products

Increased demands and the requests for specialised Roller Skates for new application, called for the development of a wide variety of different models:

- different versions for different applications:
 - the Solids for the variable short-term use
 - the Robusts for projects involving short moves
 - the Super-Robusts for permanent loads, short or long distances
- different models for different carrying capacities:
 - the Solids: 5 standard-models with single capacities from 10 to 80 metric tons
 - the Robusts: 6 standard-models with single capacities from 15 to 85 metric tons
 - the Super-Robusts: 18 standard-models with single capacities from 15 to 400 metric tons

Special designs are part of our normal business: with over 2500 different applications to date.

Conditions for safe and successful Applications

The following principles help to ensure the successful use of Roller Skates:

- Only a good strong surface will ensure the smooth running of this transportation process; additional strengthening may be required e.g. by using steel plates of at least 10 mm thickness. All our capacities are based on a steel surface, which withstands the high floor pressure of the Roller Skate Express.
- The larger the diameter of the roller in the chain, the easier it is to move the load, and less stress is placed on the steel track surface.
- Select fewer Roller Skates with larger diameter rollers, rather than more Roller Skates with smaller diameter rollers.
- Roller Skate Express is to be placed exactly parallel to the direction of movement.
- The load must be spread evenly over the carrying rollers and have equal contact with the track surface.

Maintenance

- If the Roller Skate is treated as a normal tool, no particular maintenance is necessary. The Roller Skate has a very long life.
- To prolong this long life cycle, we recommend cleaning the Roller Skate with a thin machine cleaner.
- In exceptional cases, please contact us for advice.
- If the Roller Skate Express does not serve its purpose in transporting heavy loads because:
 - the speed is insufficient
 - the floor pressure is too high
 - the rolling resistance is too high

find out more about

Heavy Duty Wheels In part 2 of the catalogue.

Roller Skate – The Robusts – Complete Transport Kit

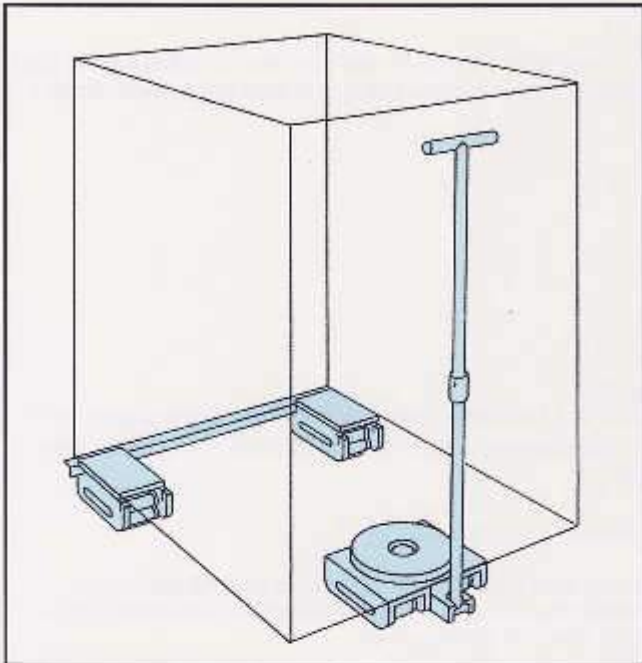

Range of application:

- With the Hercules you do not have to waste time in assembling the unit, and the low level contributes to safer working conditions.
- The Hercules makes it easier and safer to move heavy loads. 24 and 30 mm diameter rollers in the chain are available. This turntable is larger than the one in the Transport Kit N.
- For larger loads we recommend the use of a second twin Skate Roller with turntable in the front, and two normal skates as stabilisers at the back.

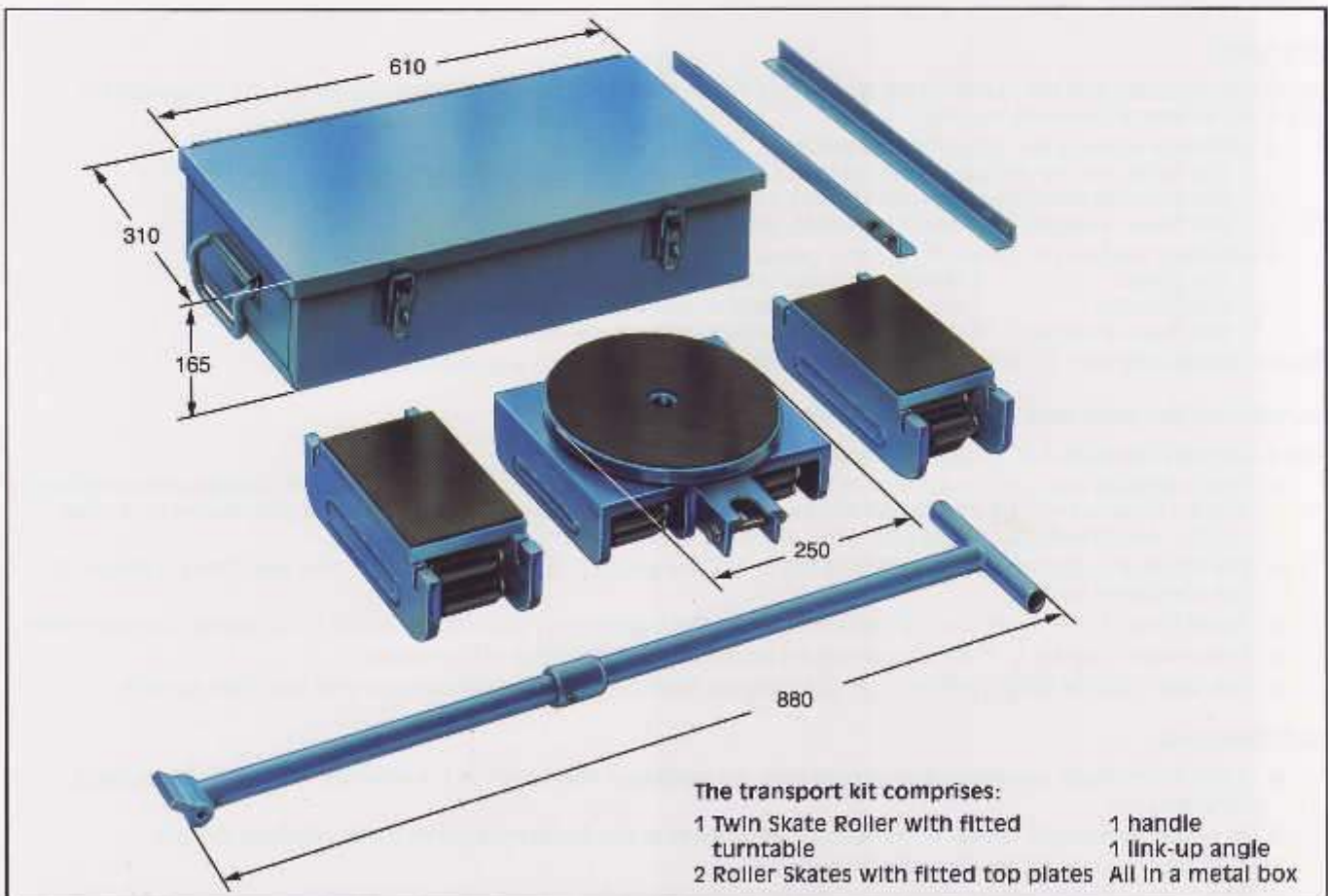

Mod. Hercules

| Mod. | Rollers Ø Twin | Rollers Ø Single | Length support | Width support | Total height | Swivel-pl. Ø | Max. load kN | Weight of set | | |
|----------|-------------------|---------------------|-------------------|------------------|-----------------|-----------------|-----------------|------------------|--|--|
| Hercules | 30 | 24 | 200 | 130 | 110 | 250 | 350 | 68 | | |

All dimensions in mm

Roller Skate – The Solids – Complete Transport Kit

Range of application:

- For short, variable transportation distances.
- Movement of moderately heavy loads, e.g. machines, parts of machines and for installation works.
- A speed of 5 m/min should not be exceeded.
- It is possible to turn corners by placing turntables on top of the Roller Skates. Handles have to be attached but only guide the load while the Roller Skates are moving.
- Minimum turning circle is 3 m.

Hints on use:

- All maximum carrying capacities are based for use on a steel surface, which withstands the pressure of the chain-roller. For safety, the carrying capacities in complete sets are calculated so that 2 Roller Skates could support the full load on uneven surfaces.
- The track surface is important for the safe transportation of the load, not the carrying capacity of the Roller Skate.
Tiles are unsuitable. Movement on tarmac and concrete is restricted. In these cases it is recommended to put a steel plate of a minimum of 10 mm thickness underneath.



- Possible problems can be avoided by choosing Roller Skate models with larger diameter rollers in the chain.
- Visual control for the alignment and direction of the load is made easier by inserting the angle iron into the slots provided on the Roller Skate.
- The difference in height of Skates with turntables is compensated by the use of packing plates.



The complete set consists of:

- 4 Roller Skates Mod. N
- 2 Turntables
- 2 packing plates
- 2 Handles
- 2 link-up bars
- 1 metal box

Complete transport kit Mod. N

| Mod. | Rollers Ø | Length support | Width support | Total height | Swivel-pl. Ø | Max. load kN | Weight of set | | | |
|------|-----------|----------------|---------------|--------------|--------------|--------------|---------------|--|--|--|
| I | 18 | 120 | 120 | 108 | 130 | 200 | 48 | | | |
| II | 24 | 120 | 120 | 117 | 130 | 300 | 56 | | | |
| III | 30 | 130 | 130 | 140 | 150 | 600 | 90 | | | |

All dimensions in mm

Accessory only for models ... N

For variable transportation

Roller Skate Express – The Solids



Swivel/Turntable

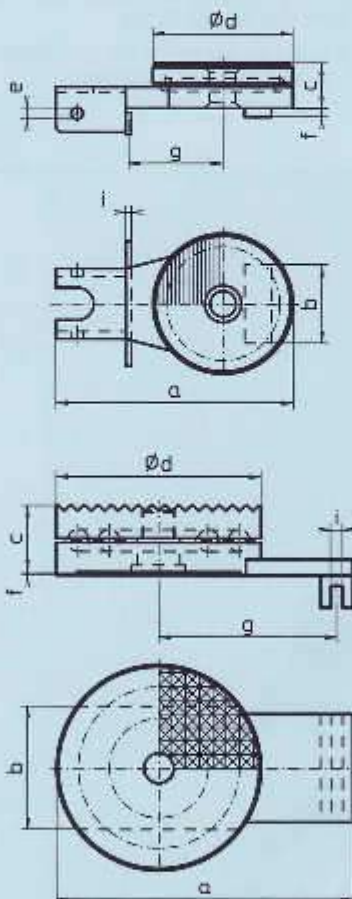

Mod.
I-III

Mod.
IV-V

Packing plate / Levelling plate

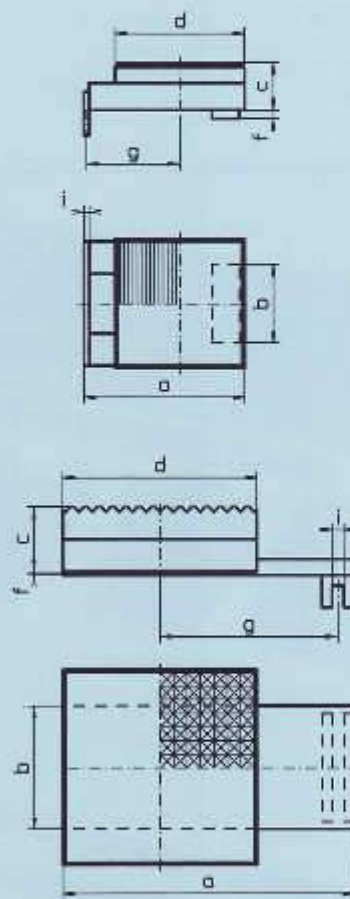

Necessary for turning corners: Turntables are to be placed on top, handle has to be attached; only guide while Roller Skate is moving. Minimum turning circle is 3 m.

Necessary for use with turntable: packing plate for compensating the difference in height between Skates with turntables and the ones without.

Turntable

| Mod. | a | b | c | Ø d | e | f | g | i | Weight kg |
|------|-----|-----|----|-----|----|---|-----|----|-----------|
| I | 220 | 73 | 42 | 130 | 11 | 8 | 87 | 5 | 4.5 |
| II | 220 | 86 | 42 | 130 | 11 | 8 | 87 | 5 | 4.5 |
| III | 250 | 96 | 48 | 150 | 11 | 8 | 108 | 5 | 6.7 |
| IV | 275 | 114 | 61 | 190 | | 3 | 165 | 11 | 13.7 |
| V | 360 | 128 | 61 | 220 | | 3 | 235 | 11 | 18.9 |

Packing plate / Levelling plate

| Mod. | a | b | c | d | f | g | i | Weight kg |
|------|-----|-----|----|-----|---|-----|----|-----------|
| I | 149 | 73 | 42 | 120 | 8 | 87 | 5 | 3.7 |
| II | 149 | 86 | 42 | 120 | 8 | 87 | 5 | 3.7 |
| III | 178 | 96 | 48 | 130 | 8 | 108 | 5 | 5.3 |
| IV | 270 | 114 | 61 | 180 | 3 | 165 | 11 | 13.8 |
| V | 350 | 128 | 61 | 200 | 3 | 235 | 11 | 18.8 |

All dimensions in mm

Roller Skate Express – The Solids

Range of application:

- For short variable ways of transportation.
- Movement of moderately heavy loads, e.g. machines, parts of machines and for installation works.
- A speed of 5 m/min should not be exceeded.
- Allows to turn corners by swivelling. Turntables are placed on top of the skate, handles are to be attached. Only guide with the handle, while the Roller Skate is moving. Minimum turning circle is 3 m.
- The difference in height of skates with the turntables is compensated for by the use of packing plates.
- Easy visual control for the alignment and direction of the load is made by inserting the angle iron into the slots provided on the Roller Skate.



Characteristics of the most sold series Express model... N:

- stable, solid, basic construction
- low level construction
- Accessories for turning corners

Hints on use:

- The track surface is important for the safe transportation of the load, not the carrying capacity of the Roller Skate. Tiles are insufficient. The movement on tarmac and concrete is restricted. In these cases a steel plate of a minimum of 10 mm thickness is recommended.

- Possible problems can be avoided by choosing Roller Skate models with a larger roller diameter within the chain.
- All maximum carrying capacities are based for use on a steel surface, which withstands the high pressure of the chain-rollers. For safety, the carrying capacities on complete sets are calculated so that on uneven surfaces 2 Roller Skates could support the full load.
- Due to the little effort required to overcome the rolling resistance (4-7 % of the total load) precautionary measures must be taken for use on inclined surfaces.

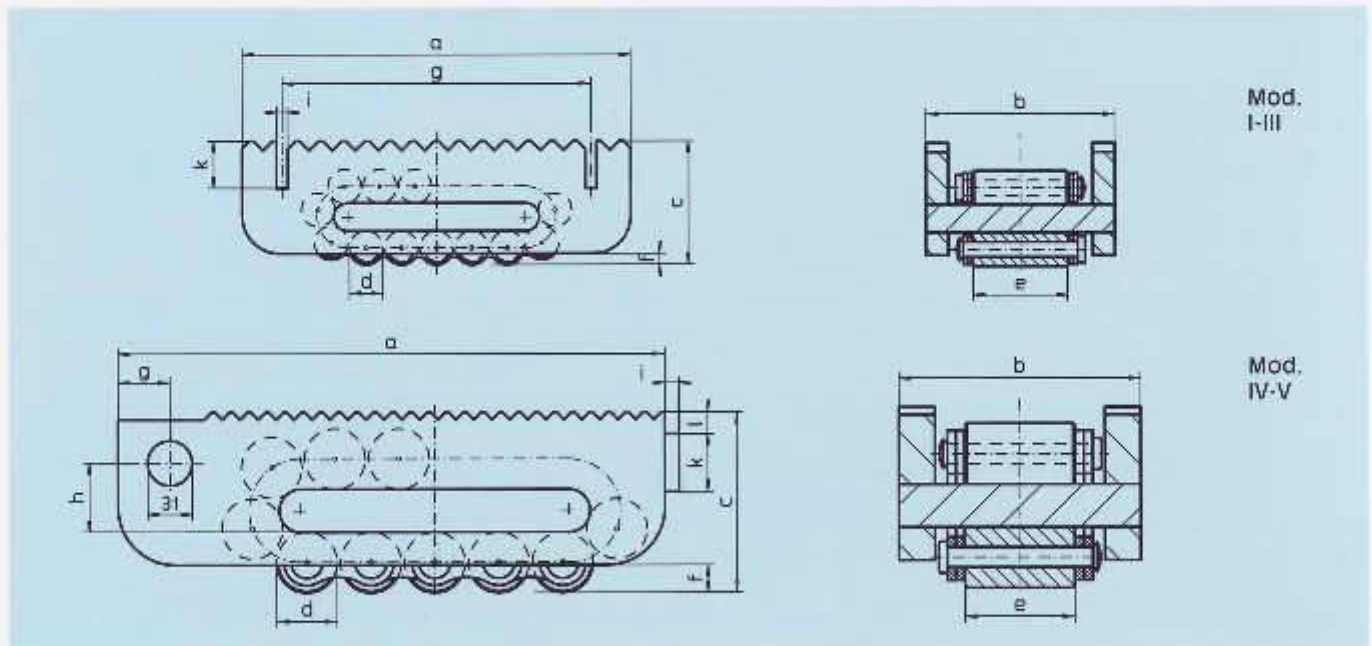

Mod. N

| Mod. | a | b | c | Ø d | e | f | g | h | i | k | l | Rollers under stress | Number of rollers | Max. load kN | Weight kg |
|------|-----|-----|-----|-----|----|----|-----|----|----|----|----|----------------------|-------------------|--------------|-----------|
| I | 240 | 100 | 66 | 18 | 51 | 6 | 167 | | 6 | 25 | | 5 | 15 | 100 | 5.2 |
| II | 220 | 113 | 75 | 24 | 60 | 10 | 180 | | 6 | 25 | | 4 | 13 | 150 | 7.3 |
| III | 270 | 130 | 92 | 30 | 68 | 10 | 217 | | 6 | 25 | | 4 | 13 | 300 | 13.0 |
| IV | 380 | 168 | 127 | 42 | 76 | 16 | 36 | 48 | 10 | 40 | 15 | 4 | 13 | 600 | 32.0 |
| V | 530 | 182 | 147 | 50 | 86 | 19 | 36 | 60 | 10 | 40 | 15 | 6 | 17 | 800 | 61.0 |

All dimensions in mm

Roller Skate Express – The Solids



Hints on use:

- If the Rollers are being used to their maximum carrying capacity or with lengthy intervals between use choose models with a hardened centre plate (= model C-H).
- In case of possible overload, choose chain roller material 50CrV4 (B.S. 735 A 50; SAE 6150) (= models C-H-50CrV4).
- Maximum speed: 5 m/min.
- The rolling resistance depends on the track. For smaller models I-III 7-5 %, for larger models 5-3 % of the total load.
- If necessary this model can be reduced in height for special applications.
- For scaffolding application the chain alone can be used, (length according to customers' specification).

Range of application:

- For short distances.
- If possible on suitable tracks, e.g. crane rails or steel beams.
- Movement of moderately heavy loads e.g. to transport materials in ovens, for shuttering, concreting or stocking techniques.
- Use as a conveyor, when the load is moving and the Roller Skates are fixed.
- Ideal model for confined spaces.

Characteristics of the Series of model... C:

- Stable, solid basic construction.
- Low level construction and smooth top achieved after welding, models C and B are of the same height.
- Can be welded to the load to ensure Roller Skates and load are firmly connected.
- Available with hardened centre plate (= models C-H) or additionally with higher tensile roller material 50CrV4 (= SAE 6150) (= models C-H-50CrV4).

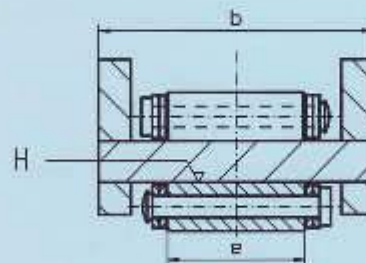
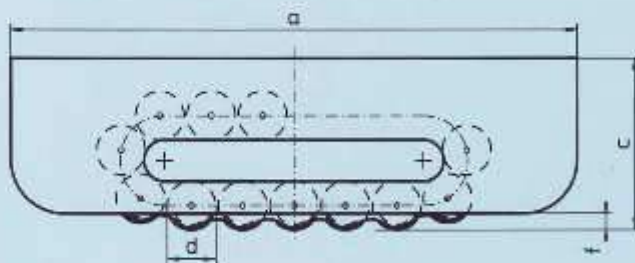

Mod. C, C-H (H = hardened and machined centre plate), C-H-50CrV4 (roller material 50CrV4)

| Mod. | a | b | c | Ø d | e | f | | | | | Rollers under stress | Number of Rollers | Maximum load kN | Weight kg |
|------|-----|-----|-----|-----|----|----|--|--|--|--|----------------------|-------------------|-----------------|-----------|
| I | 210 | 100 | 63 | 18 | 51 | 6 | | | | | 5 | 15 | 100 | 5.0 |
| II | 220 | 113 | 73 | 24 | 60 | 10 | | | | | 4 | 13 | 150 | 7.0 |
| III | 270 | 130 | 90 | 30 | 68 | 10 | | | | | 4 | 13 | 300 | 12.5 |
| IV | 380 | 168 | 126 | 42 | 76 | 19 | | | | | 4 | 13 | 600 | 32.0 |
| V | 530 | 182 | 146 | 50 | 86 | 19 | | | | | 6 | 17 | 800 | 61.0 |

All dimensions in mm

Roller Skate Express – The Robusts

Range of application:

- For short distances.
- If possible on suitable tracks, e.g. crane rails or steel beams.
- Movement of heavy loads in mining, steel industry, machine construction, bridge construction and other heavy industrial plants.
- Use as a conveyor, when the load is moving and the Roller Skates are fixed.
- Low level construction overcomes problems in confined space.

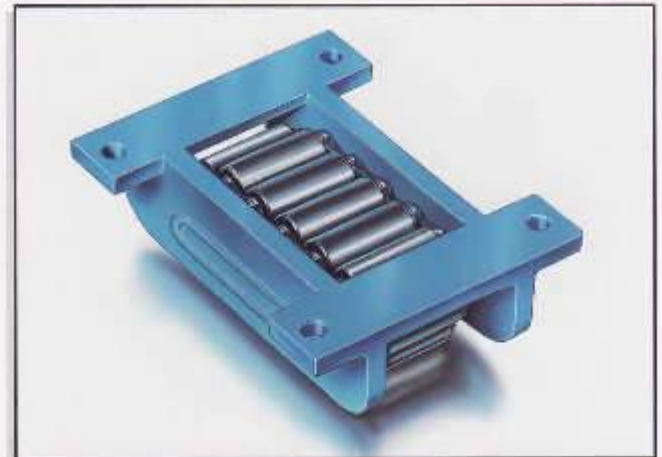

Characteristics of the series of model...B:

- Stable, solid basic construction.
- Low level is achieved by recessing the mounting plates into side walls. Model... B and ... C are the same height.
- More stability by firmly bolting the Skates to the load.
- Available with hardened centre plate (= models B-H) or additionally with higher tensile roller material 50CrV4 (= SAE 6150) (= models B-H-50CrV4).

Hints on use:

- If the Rollers are being used to their maximum carrying capacity or with lengthy intervals between use choose models with a hardened centre plate (= model B-H).
- In case of possible overload, choose chain roller material 50CrV4 (B.S. 735 A 50; SAE 6150) (= models B-H-50CrV4).
- Maximum speed: 5 m/min.
- The rolling resistance depends on the track. For smaller models I-III 7-5 %, for larger models 5-3 % of the total load.
- Can be arranged with guide rollers (see drawing 11+12).

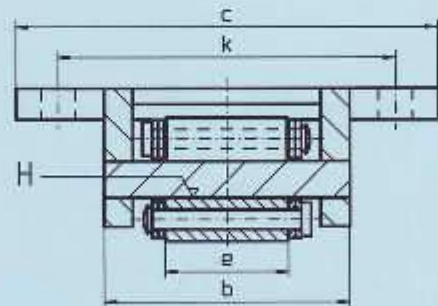
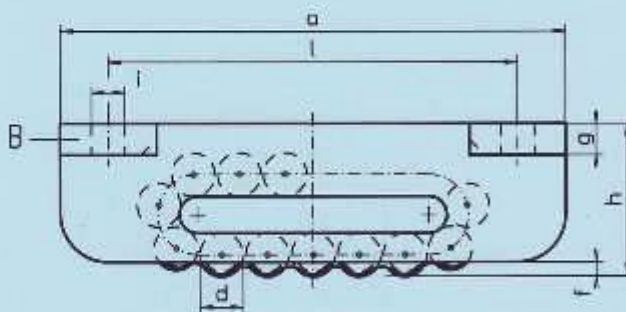

Mod. B, B-H (H = hardened and machined centre plate), B-H-50CrV4 (roller material 50CrV4)

| Mod. | a | b | c | Ø d | e | f | g | h | Ø i | k | l | Rollers under stress | Number of Rollers | Maximum load kN | Weight kg |
|------|-----|-----|-----|-----|----|----|----|-----|-----|-----|-----|----------------------|-------------------|-----------------|-----------|
| I | 210 | 100 | 175 | 18 | 51 | 6 | 13 | 63 | 14 | 140 | 170 | 5 | 15 | 100 | 6.2 |
| II | 220 | 113 | 190 | 24 | 60 | 10 | 14 | 73 | 14 | 155 | 180 | 4 | 13 | 150 | 8.4 |
| III | 270 | 130 | 210 | 30 | 68 | 10 | 14 | 90 | 18 | 175 | 220 | 4 | 13 | 300 | 14.1 |
| IV | 380 | 168 | 270 | 42 | 76 | 19 | 19 | 126 | 22 | 220 | 320 | 4 | 13 | 600 | 36.5 |
| V | 530 | 182 | 300 | 50 | 86 | 19 | 19 | 146 | 22 | 240 | 470 | 6 | 17 | 800 | 66.4 |

All Dimensions in mm

Roller Skate Express – The Robusts

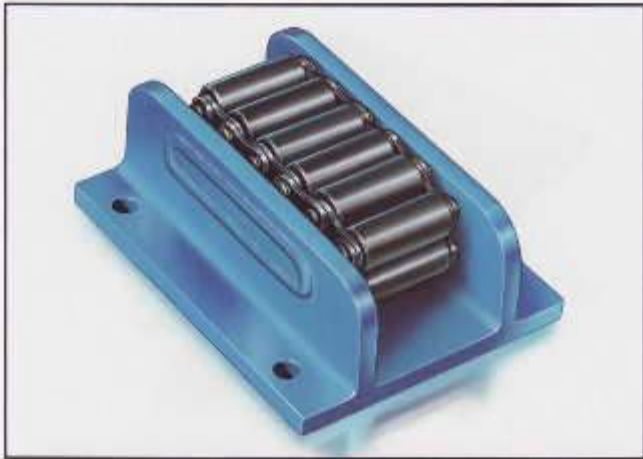

Hints on use:

- Models I-IIIv have 4 bolt holes as standard.
- If the Rollers are being used to their maximum carrying capacity or with lengthy intervals between use choose models with a hardened centre plate (= model A-H).
- In case of possible overload, choose chain roller material 50CrV4 (B.S. 735 A 50; SAE 6150) (= models A-H-50CrV4).
- Maximum speed: 5 m/min.
- The rolling resistance depends on the track.
For smaller models I-IIIv 7-5 %, for larger models 5-3 % of the total load.
- Can be arranged with guide rollers (see drawing 11+12).
- Location of the fixing holes can be arranged to suit customers' requirements.
- Optional in galvanised or stainless steel construction.

Range of application:

- For short distances.
- If possible on suitable tracks, e.g. crane rails or steel beams.
- Movement of heavy loads in mining, steel industry, machine construction, bridge construction and the ship building industry.
- Use as a conveyor, when the load is moving and the Roller Skates are fixed.
- Often used on construction sites.

Characteristics of the series of model...A:

- Robust construction.
- Low level construction with higher carrying capacity, exchangeable in outer dimensions with models ...AS+ ...AM.
- More stability achieved if load is firmly bolted to Roller Skate.
- Available with hardened centre plate (= models A-H) or additionally with higher tensile roller material 50CrV4 (= SAE 6150) (= models A-H-50CrV4).

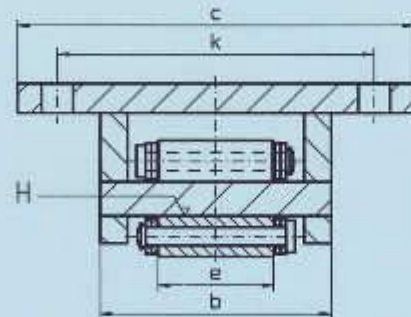
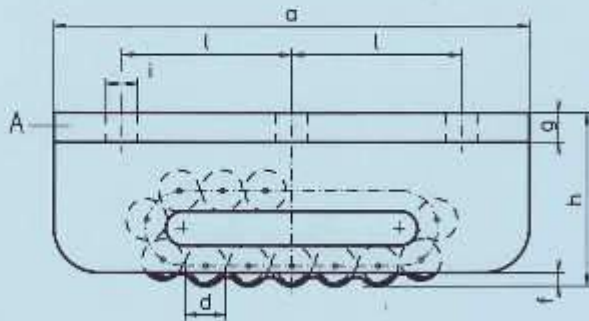

Mod. A, A-H (H = hardened and machined centre plate), A-H-50CrV4 (roller material 50CrV4)

| Mod. | a | b | c | Ø d | e | f | g | h | Ø l | k | l | Rollers under stress | Number of Rollers | Maximum load kN | Weight kg |
|------|-----|-----|-----|-----|----|----|----|-----|-----|-----|-----|----------------------|-------------------|-----------------|-----------|
| I | 210 | 100 | 175 | 18 | 51 | 6 | 13 | 76 | 14 | 140 | 75 | 5 | 15 | 150 | 8.9 |
| II | 220 | 113 | 190 | 24 | 60 | 10 | 14 | 87 | 14 | 155 | 75 | 4 | 13 | 200 | 11.7 |
| III | 270 | 130 | 210 | 30 | 68 | 10 | 14 | 104 | 18 | 175 | 95 | 4 | 13 | 400 | 19.3 |
| IIIv | 320 | 140 | 220 | 30 | 68 | 10 | 18 | 115 | 18 | 180 | 120 | 6 | 17 | 500 | 29.0 |
| IV | 380 | 168 | 270 | 42 | 76 | 19 | 19 | 145 | 22 | 220 | 140 | 4 | 13 | 650 | 51.0 |
| V | 530 | 182 | 300 | 50 | 86 | 19 | 19 | 165 | 22 | 240 | 205 | 6 | 17 | 850 | 92.0 |

All dimensions in mm

Roller Skate Express – The Super-Robusts

Range of application:

- For longer distances and/or permanent loads.
- On suitable tracks, crane rails or steel beams.
- Movement of heavy loads for longer distances or for progressive shifting of scaffolding and shuttering in bridge construction. Also used for hangar doors (hardened shelters), as crawler tracks, in nuclear power stations, in Institutes for nuclear research, on oil rigs, in the ship building industry and for tunnel construction.
- Use as a conveyor, when the load is moving and the Roller Skates are fixed.



Characteristics of the series of model...AS:

- Extra robust construction.
- Low level construction, exchangeable in outer dimensions with model ...AM and ...A.
- More stability achieved, if load is firmly bolted to Roller Skates.
- More stable operation and distribution of load.
- **Reduced wear by centre plate chain guide** (no contact between chain and side walls, no wear on rivet heads).

* Sticker on every Roller Skate with 5-guide:

Attention! This model has a chain guide in the central bridge for the roller chain. Ensure that all rollers run exactly inside the chain guide before setting down.

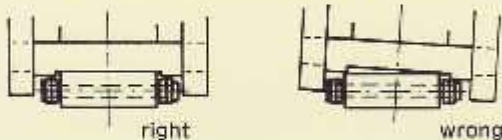

Hints on use:

- Models I-IIIv have 4 bolt holes as standard.
- If problems of load distribution occur e.g. by wind forces, it is necessary to choose model AS-H-50CrV4
- Maximum speed: 5 m/min.
- The rolling resistance depends on the track. For smaller models I-IIIv 7-5 %, for larger models 5-3 % of the total load.
- Available with guide rollers (see drawing 11+12).
- Location of the fixing holes can be arranged to suit customers' requirements.
- Optional in galvanised or stainless steel construction.
- Several models for off-shore purposes approved by LRS, ABS and Dnv.

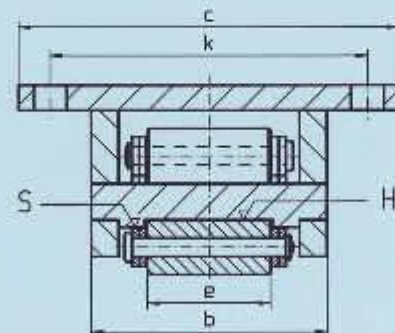
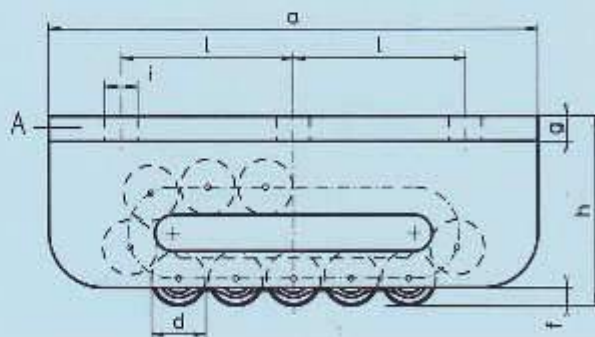

Mod. AS-H (H = hardened and machined centre plate), **AS-H-50CrV4** (roller material 50CrV4)

| Mod. | a | b | c | Ø d | e | f | g | h | Ø l | k | l | Rollers under stress | Number of Rollers | Maximum load kN | Weight kg |
|------|-----|-----|-----|-----|-----|----|----|-----|-----|-----|-----|----------------------|-------------------|-----------------|-----------|
| III | 270 | 130 | 210 | 30 | 68 | 10 | 14 | 104 | 18 | 175 | 95 | 4 | 13 | 400 | 19.6 |
| IIIv | 320 | 140 | 220 | 30 | 68 | 10 | 18 | 115 | 18 | 180 | 120 | 6 | 17 | 500 | 29.5 |
| IV | 380 | 168 | 270 | 42 | 76 | 19 | 19 | 145 | 22 | 220 | 140 | 4 | 13 | 650 | 51.7 |
| V | 530 | 182 | 300 | 50 | 86 | 19 | 19 | 165 | 22 | 240 | 205 | 6 | 17 | 850 | 93.0 |
| VL | 580 | 182 | 300 | 50 | 86 | 19 | 23 | 170 | 26 | 250 | 250 | 8 | 21 | 1000 | 109.0 |
| Vv | 650 | 205 | 350 | 50 | 100 | 20 | 28 | 190 | 26 | 280 | 240 | 9 | 23 | 1500 | 162.0 |
| VI | 900 | 205 | 380 | 50 | 100 | 20 | 38 | 200 | 33 | 300 | 360 | 13 | 31 | 2000 | 266.0 |

All Dimensions in mm

Roller Skate Express – The Super-Robusts



Hints on use:

- Check with the manufacturer before selection of Skates for use in a vertical position.
- Models I-IIIv have 4 bolt holes as standard.
- If problems of load distribution occur e.g. by wind forces, it is necessary to select model AM-H-50CrV4.
- Maximum speed: 5 m/min.
- The rolling resistance depends on the track. For smaller models I-IIIv 7–5 %, for larger models 5–3 % of the total load.
- Available with guide rollers (see drawing 11+12).
- Location of the fixing holes can be arranged to suit customers' requirements.
- Optional in galvanised or stainless steel construction.

Range of application:

- For longer distances and/or permanent loads.
- On suitable tracks, crane rails or steel beams.
- Movement of heavy loads for longer distances or for a long time e.g. for movements as a machine component, heavy duty telescope, guidance on component for very high radial force e.g. in ship building, in the machine engineering industry.
- Use as a conveyor, when the load is moving and the Roller Skates are fixed e.g. rolling table for heavy pallets of tube producer.
- Origin of concept: application in machine construction.

Characteristics of the series of model...AM:

- Extra robust construction.
- Low profile, exchangeable in outer dimensions with model...AS and ...A.
- More stability achieved, if load is firmly bolted to Roller Skates.
- More stable operation and distribution of load.
- Reduced wear by centre plate chain guide (no contact between chain and side walls, no wear to rivet heads).

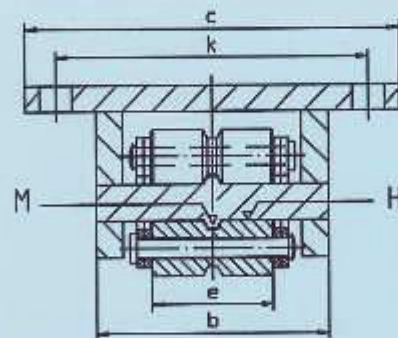
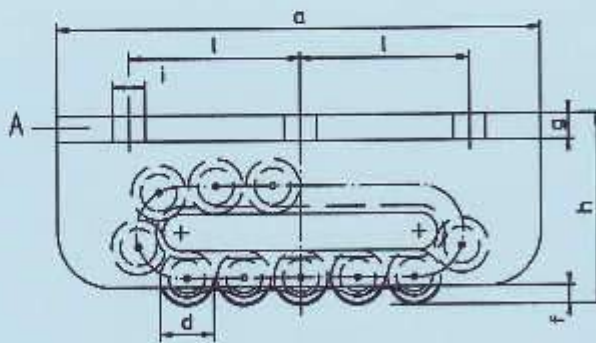

Mod. AM-H (H = hardened and machined centre plate), AM-H-50CrV4 (roller material 50CrV4)

| Mod. | a | b | c | Ø d | e | f | g | h | Ø i | k | l | Rollers under stress | Number of Rollers | Maximum load kN | Weight kg |
|------|-----|-----|-----|-----|-----|----|----|-----|-----|-----|-----|----------------------|-------------------|-----------------|-----------|
| I | 210 | 100 | 175 | 18 | 51 | 6 | 13 | 76 | 14 | 140 | 75 | 5 | 15 | 125 | 8.8 |
| II | 220 | 113 | 190 | 24 | 60 | 10 | 14 | 87 | 14 | 155 | 75 | 4 | 13 | 170 | 11.5 |
| III | 270 | 130 | 210 | 30 | 68 | 10 | 14 | 104 | 18 | 175 | 95 | 4 | 13 | 330 | 19.0 |
| IIIv | 320 | 140 | 220 | 30 | 68 | 10 | 18 | 115 | 18 | 180 | 120 | 6 | 17 | 420 | 28.5 |
| IV | 380 | 168 | 270 | 42 | 76 | 19 | 19 | 145 | 22 | 220 | 140 | 4 | 13 | 530 | 50.0 |
| V | 530 | 182 | 300 | 50 | 86 | 19 | 19 | 165 | 22 | 240 | 205 | 6 | 17 | 690 | 89.5 |
| VL | 580 | 182 | 300 | 50 | 86 | 19 | 23 | 170 | 26 | 250 | 250 | 8 | 21 | 880 | 104.0 |
| Vv | 650 | 205 | 350 | 50 | 100 | 20 | 28 | 190 | 26 | 280 | 240 | 9 | 23 | 1250 | 156.0 |
| VI | 900 | 205 | 380 | 50 | 100 | 20 | 38 | 200 | 33 | 300 | 360 | 13 | 31 | 1650 | 237.0 |

All dimensions in mm

Roller Skate Express – The Super-Robusts

Range of application:

- For longer distances and repeat journeys with permanent loads.
- On suitable tracks like crane rails or steel beams.
- For extreme load bearing points.
- Suitable for limited space.
- Often used for bridge construction or for mobile equipment to support hydraulic valves.
- Use as a conveyor, when the load is moving and the Roller Skates are fixed.
- Triple Roller Skates or Multiple Roller Skates on request.
- For further information please see pages 8-10.

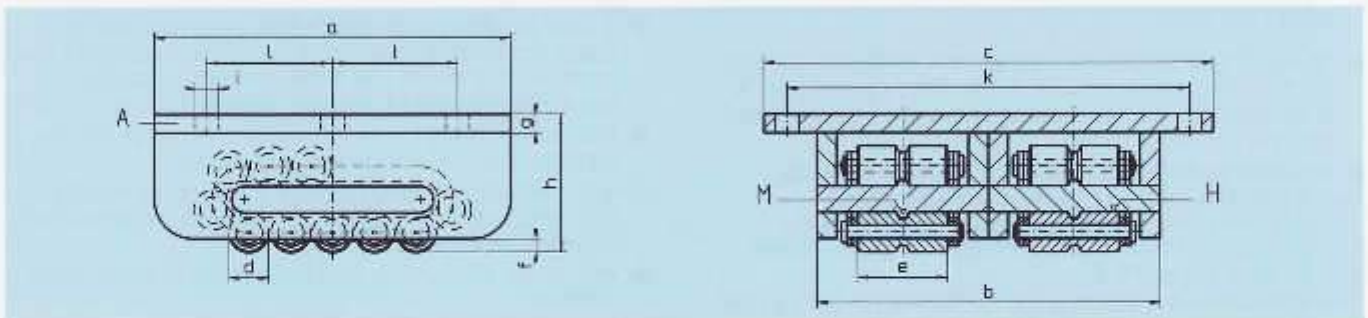

Mod. ZAM-H (H = hardened and machined centre plate), **ZAM-H-50CrV4** (roller material 50CrV4)

| Mod. | a | b | c | Ø d | e | f | g | h | Ø i | k | l | Rollers under stress | Number of Rollers | Maximum load kN | Weight kg |
|------|-----|-----|-----|-----|-----|----|----|-----|-----|-----|-----|----------------------|-------------------|-----------------|-----------|
| I | 210 | 200 | 280 | 18 | 51 | 6 | 13 | 76 | 14 | 245 | 75 | 2 x 5 | 2 x 15 | 250 | 16,0 |
| II | 220 | 226 | 305 | 24 | 60 | 10 | 14 | 87 | 14 | 270 | 80 | 2 x 4 | 2 x 13 | 340 | 22,0 |
| III | 270 | 260 | 340 | 30 | 68 | 10 | 14 | 104 | 18 | 305 | 95 | 2 x 4 | 2 x 13 | 660 | 35,0 |
| IIIv | 320 | 280 | 360 | 30 | 68 | 10 | 18 | 115 | 18 | 325 | 120 | 2 x 6 | 2 x 17 | 840 | 55,5 |
| IV | 380 | 336 | 440 | 42 | 76 | 19 | 19 | 145 | 22 | 390 | 150 | 2 x 4 | 2 x 13 | 1060 | 92,5 |
| V | 530 | 364 | 480 | 50 | 86 | 19 | 19 | 165 | 22 | 430 | 210 | 2 x 6 | 2 x 17 | 1380 | 168,0 |
| VL | 580 | 364 | 480 | 50 | 86 | 19 | 23 | 170 | 26 | 430 | 250 | 2 x 8 | 2 x 21 | 1760 | 197,0 |
| Vv | 650 | 410 | 560 | 50 | 100 | 20 | 28 | 190 | 26 | 490 | 240 | 2 x 9 | 2 x 23 | 2500 | 294,0 |
| VI | 900 | 410 | 590 | 50 | 100 | 20 | 38 | 200 | 33 | 500 | 360 | 2 x 13 | 2 x 31 | 3300 | 432,0 |

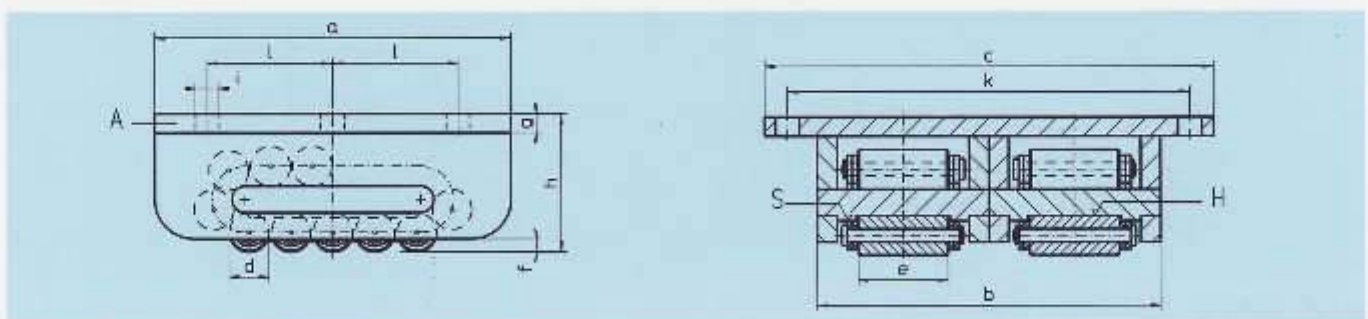

Mod. ZAS-H (H = hardened and machined centre plate), **ZAS-H-50CrV4** (roller material 50CrV4)

| Mod. | a | b | c | Ø d | e | f | g | h | Ø i | k | l | Rollers under stress | Number of Rollers | Maximum load kN | Weight kg |
|------|-----|-----|-----|-----|-----|----|----|-----|-----|-----|-----|----------------------|-------------------|-----------------|-----------|
| III | 270 | 260 | 340 | 30 | 68 | 10 | 14 | 104 | 18 | 305 | 95 | 2 x 4 | 2 x 13 | 800 | 36,2 |
| IIIv | 320 | 280 | 360 | 30 | 68 | 10 | 18 | 115 | 18 | 325 | 120 | 2 x 6 | 2 x 17 | 1000 | 57,5 |
| IV | 380 | 336 | 440 | 42 | 76 | 19 | 19 | 145 | 22 | 390 | 150 | 2 x 4 | 2 x 13 | 1300 | 96,0 |
| V | 530 | 364 | 480 | 50 | 86 | 19 | 19 | 165 | 22 | 430 | 210 | 2 x 6 | 2 x 17 | 1700 | 175,0 |
| VL | 580 | 364 | 480 | 50 | 86 | 19 | 23 | 170 | 26 | 430 | 250 | 2 x 8 | 2 x 21 | 2000 | 207,0 |
| Vv | 650 | 410 | 560 | 50 | 100 | 20 | 28 | 190 | 26 | 490 | 240 | 2 x 9 | 2 x 23 | 3000 | 305,0 |
| VI | 900 | 410 | 590 | 50 | 100 | 20 | 38 | 200 | 33 | 500 | 360 | 2 x 13 | 2 x 31 | 4000 | 485,0 |

All dimensions in mm

Accessory: lateral guide roller

For permanent loads / longer distances

Roller Skate – The Robusts and The Super-Robusts

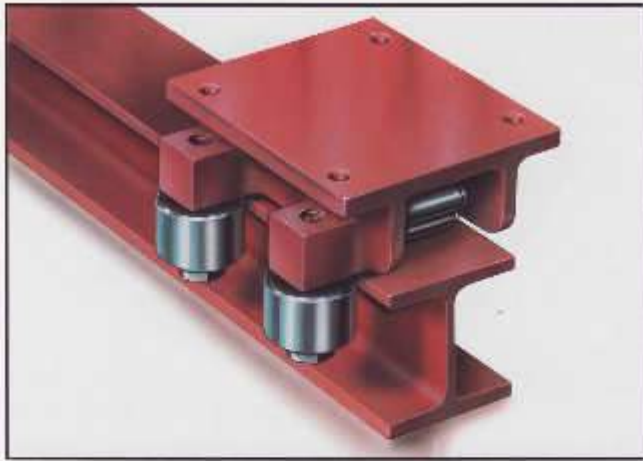

Hints on use:

- To select suitable Skate – determine details of the rail track or determine dimension 'X', where dimension 'X' is the distance between the inner edge of guide rollers and the centre of the Roller Skate.
- To select suitable arrangement of guide roller(s):
 - if parallelism of beams or rails is uncertain, it is advisable to locate the guide roller on one profile edge only and then employ 4 guide rollers on each Skate (FR-E);
 - if parallelism is assured it is sufficient to use 2 guide rollers on each Skate (FR-C), bearing on both tracks.

Range of application:

- For longer distances and repeat journeys with permanent loads.
- On suitable tracks such as crane rails or steel beams.
- Numbers and arrangement of the guide rollers according to drawing 11+12.

Characteristics of the guide rollers ... FR:

- Robust, almost maintenance free; welded construction able to maintain a defined direction.
- Made to measure according to customers' requirements and/or the specific track.
- Minimum specification for Skates: hardened centre plate.
- If lateral guide rollers cannot be mounted due to space limitations, the use of lead rollers, mounted in front of (or behind) the Skate to suit the particular rail is recommended (see photo page 22).
- Position of fixing holes in top plate of Skate can be arranged to suit customers' requirement.
- If the hexagonal head of small guide roller spindle for model I-IIIv creates space problems, construction can be modified.
- For model IIIv there is also the option of large guide roller(s).
- Maximum speed: 5 m/min.

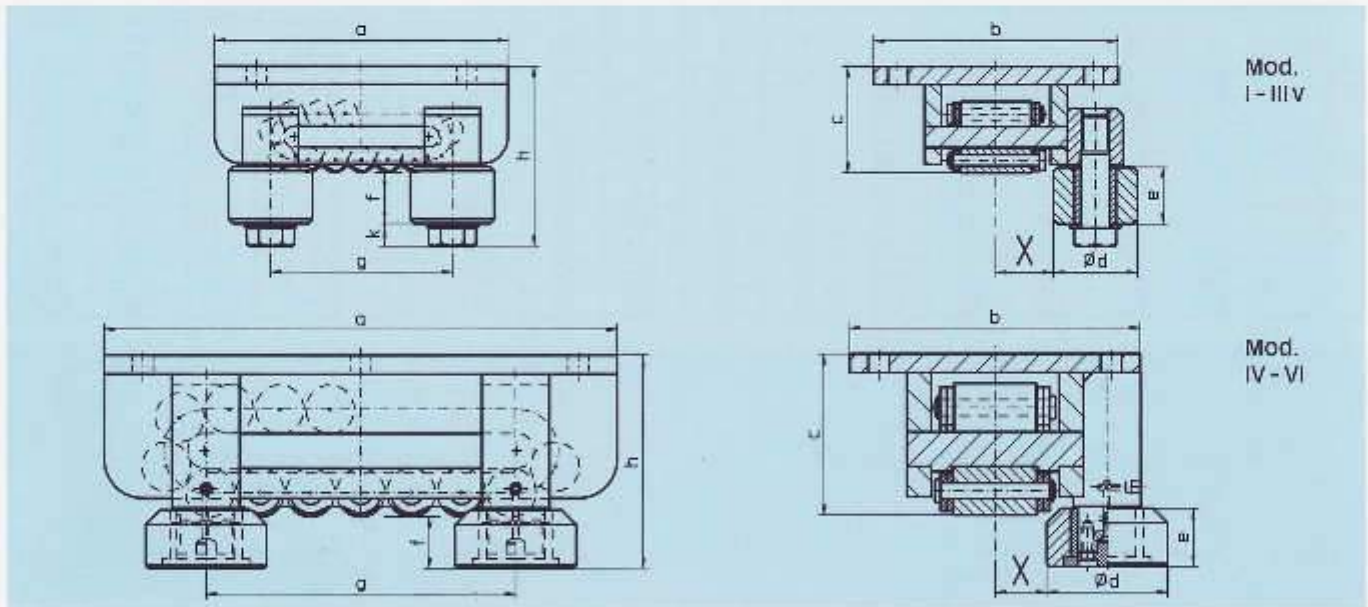

Mod. A-H-FR-, AS-H-FR-, AM-H-FR-

| Mod. | a | b | c | Ød | e | f | g | h | k | X min. | X max. | Admissible Radial Force per Guide Roller |
|------|-----|-----|-----|-----|----|----|-----|-----|----|--------|--------|--|
| I | 210 | 175 | 76 | 60 | 40 | 36 | 130 | 128 | 16 | 35 | 80 | 10 |
| II | 220 | 190 | 87 | 60 | 40 | 32 | 140 | 135 | 16 | 42 | 90 | 10 |
| III | 270 | 210 | 104 | 60 | 40 | 32 | 180 | 152 | 16 | 50 | 110 | 10 |
| IIIv | 320 | 220 | 115 | 60 | 40 | 32 | 230 | 163 | 16 | 55 | 115 | 10 |
| IV | 380 | 270 | 145 | 125 | 60 | 50 | 160 | 195 | - | 45 | 150 | 100 |
| V | 530 | 300 | 165 | 125 | 60 | 50 | 280 | 215 | - | 50 | 160 | 100 |
| VL | 580 | 300 | 170 | 125 | 60 | 50 | 340 | 220 | - | 50 | 160 | 100 |
| Vv | 650 | 350 | 190 | 170 | 60 | 50 | 340 | 240 | - | 50 | 170 | 150 |
| VI | 900 | 380 | 200 | 170 | 60 | 50 | 550 | 250 | - | 50 | 170 | 150 |

All dimensions in mm

Roller Skate – The Robusts and The Super-Robusts

Range of application:

- For longer distances and repeat journeys with permanent loads.
- On suitable tracks such as crane rails or steel beams.
- Numbers and arrangement of the guide rollers according to drawing 11+12.

Hints on use:

- To select suitable arrangement of guide roller(s):
 - if parallelism of beams or rails is uncertain, it is advisable to locate the guide roller on one profile edge only and then employ 4 guide rollers on each Skate (FR-E);
 - If parallelism is assured it is sufficient to use 2 guide rollers on each Skate (FR-C), bearing on both tracks.
- If lateral guide rollers cannot be mounted due to space limitations, the use of lead rollers, mounted in front of (or behind) the Skate to suit the particular rail profile is recommended (see photo page 22).

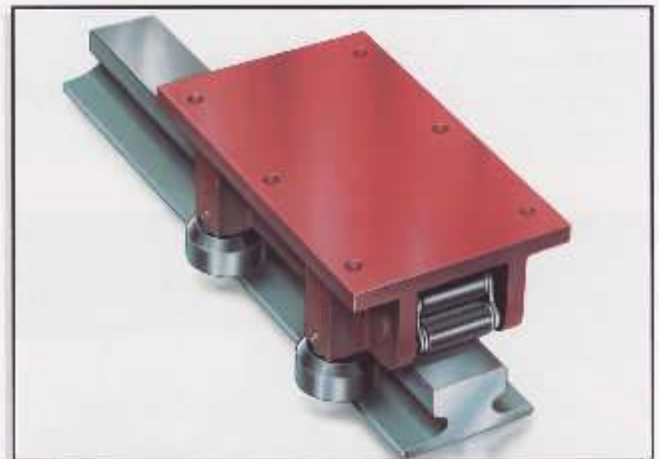

- Position of fixing holes in top plate of Skate can be arranged to suit customers' requirement.

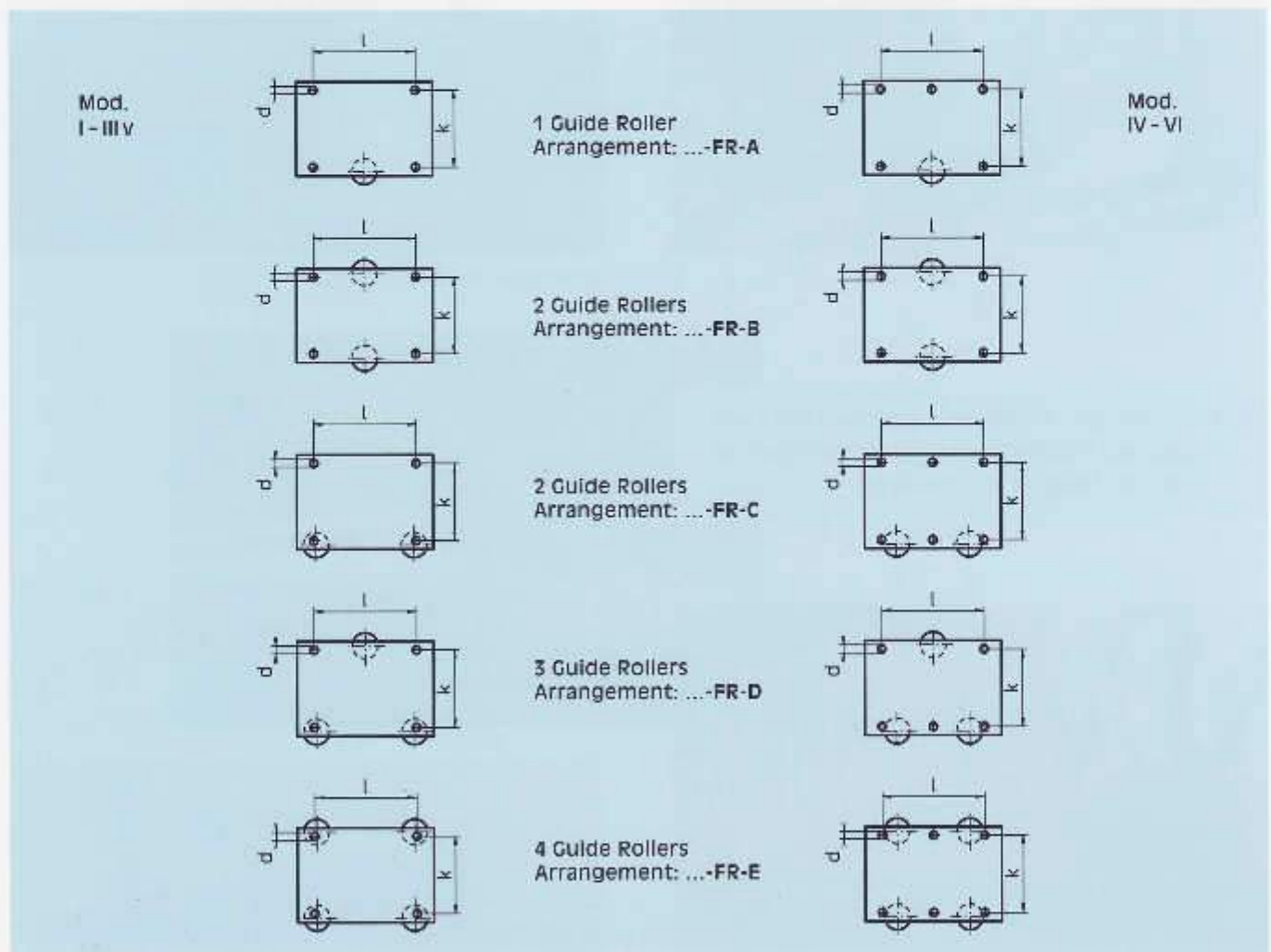

Mod. A-H-FR-, AS-H-FR-, AM-H-FR-

| Mod. | I | II | III | IIIv | IV | V | VL | Vv | VI | Mod. |
|------|-----|-----|-----|------|-----|-----|-----|-----|-----|------|
| Ø d | 14 | 14 | 18 | 18 | 22 | 22 | 26 | 26 | 33 | Ø d |
| k | 140 | 155 | 175 | 180 | 220 | 240 | 250 | 280 | 300 | k |
| l | 150 | 150 | 190 | 240 | 280 | 410 | 500 | 480 | 720 | l |

All dimensions in mm

Universal application of Roller Skate Express

- Movement of a winding tower in China weighing 520 tonnes using Roller Skates.



Reference: Slemag Transplan

- Loading an off-shore construction part weighing 110 tonnes into an aeroplane with the help of Roller Skates.



Universal application of Roller Skate Express

- The positions of 80 tonnes partitions on a container ship are adjustable when Roller Skates are employed.

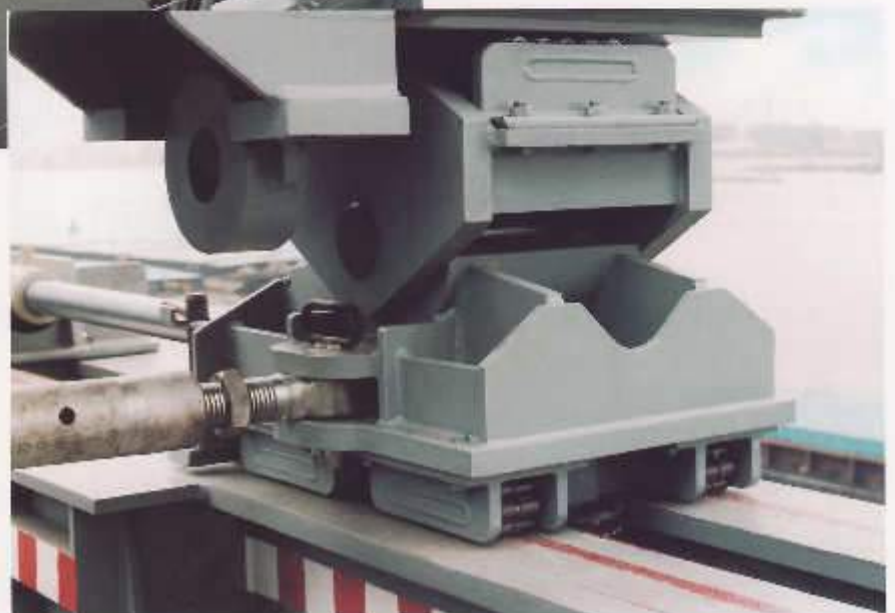

Universal application of Roller Skate Express



■ Positioning of a tooling machine

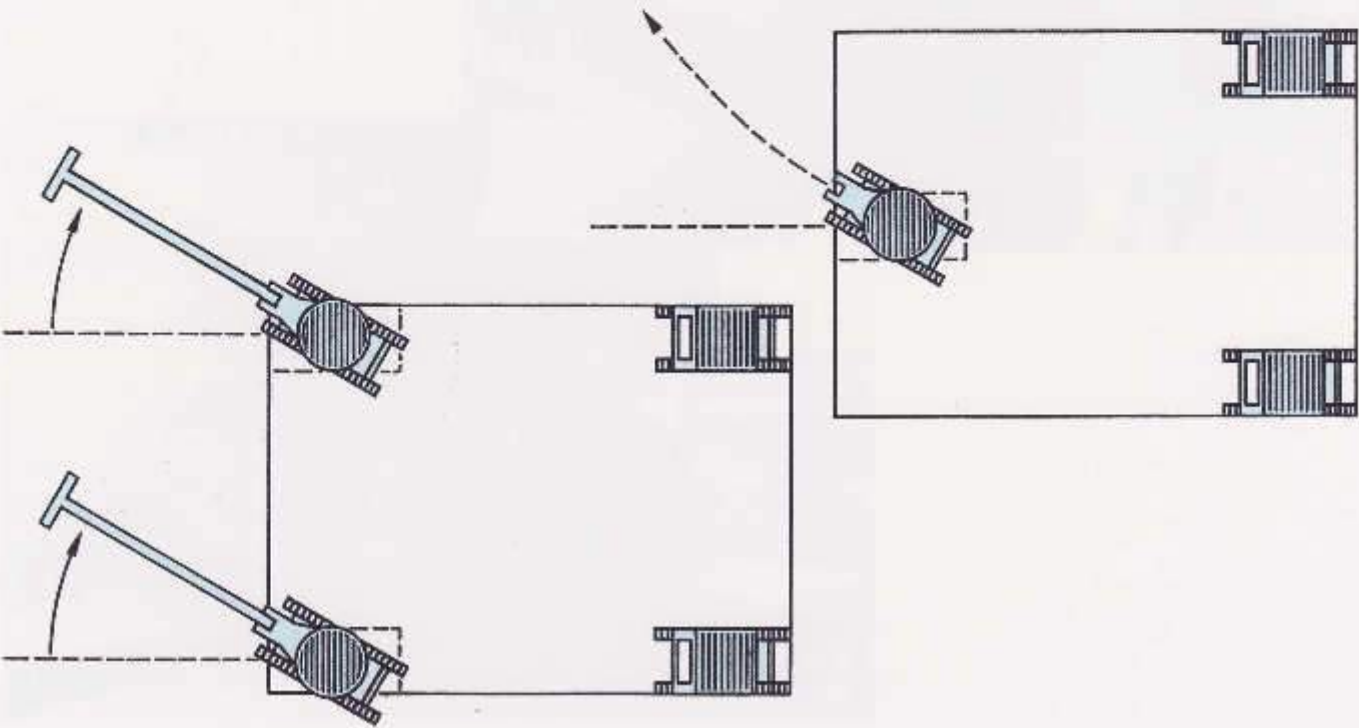

Universal application of Roller Skate Express



Reference: Photo CERN/Geneva

■ Roller Skates Model V AS-H-50CrV4 in the Nuclear Research Centre (CERN) in Geneva

Universal application of Roller Skate Express

- Used in the construction of the ZEUS-Experiment at DESY, Hamburg (nuclear research).

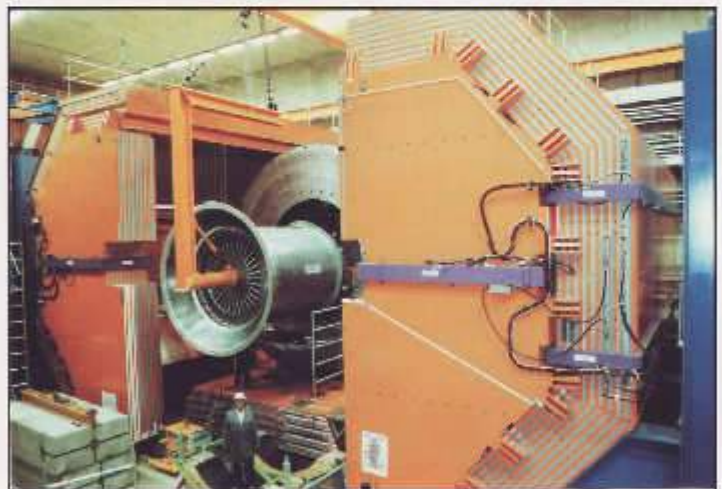

Reference: Photo DESY/Hamburg

Universal application of Roller Skate Express



- Roller Skates to solve the stocking and moving problems for the 3600 tonne experiments ZEUS and HERA.



- Roller Skate with a centre-plate, which is adapted to the diameter of the super-conducting coil.



Reference: Photo DESY/Hamburg

Universal application of Roller Skate Express



- Displacement of a 4000 tonnes blast furnace in China with 8 Twin Roller Skates



Universal application of Roller Skate Express



- Movable 800 tonnes spectators' stand at Schalke (Arena) in Germany

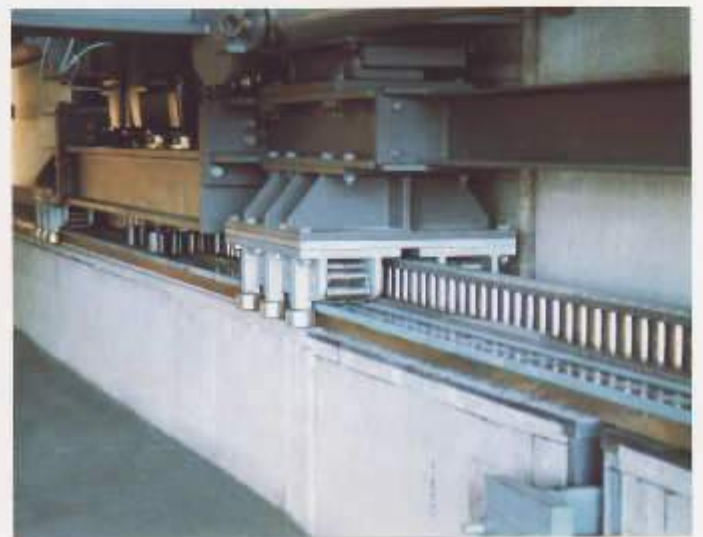

Roller Skates made to measure



with swivelling top-plate

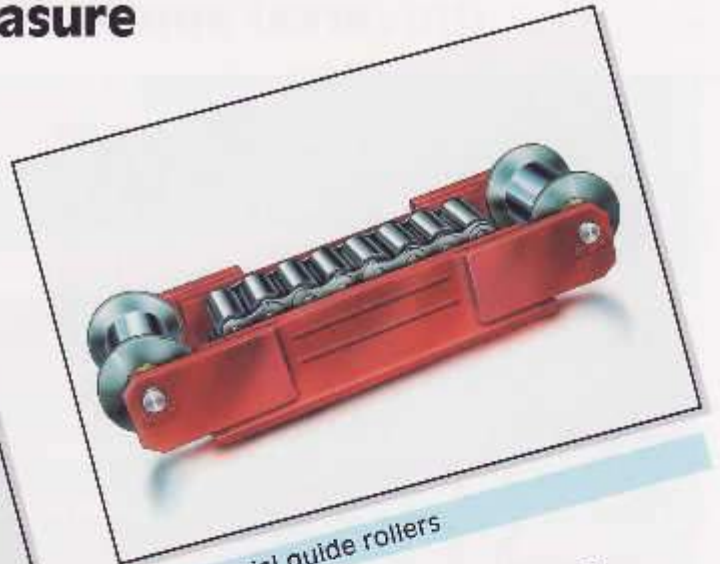

with special guide rollers

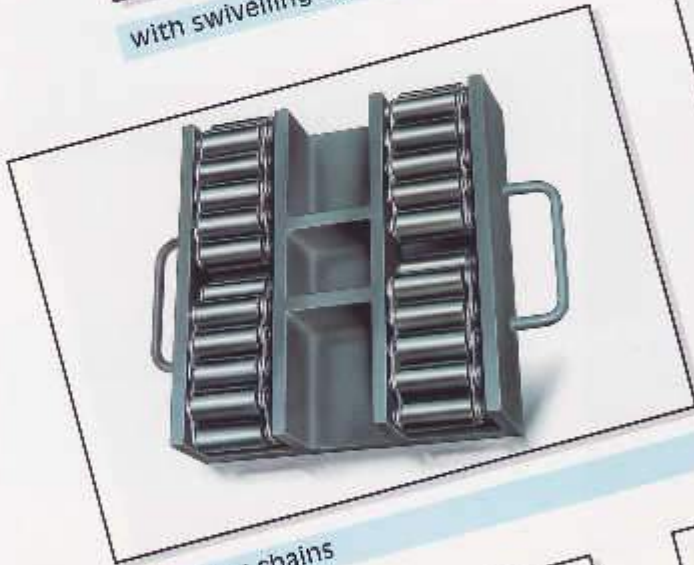

with four chains



with curved centre-plate



with removable guide rollers



with guide rollers to run in channels

Roller Skates made to measure

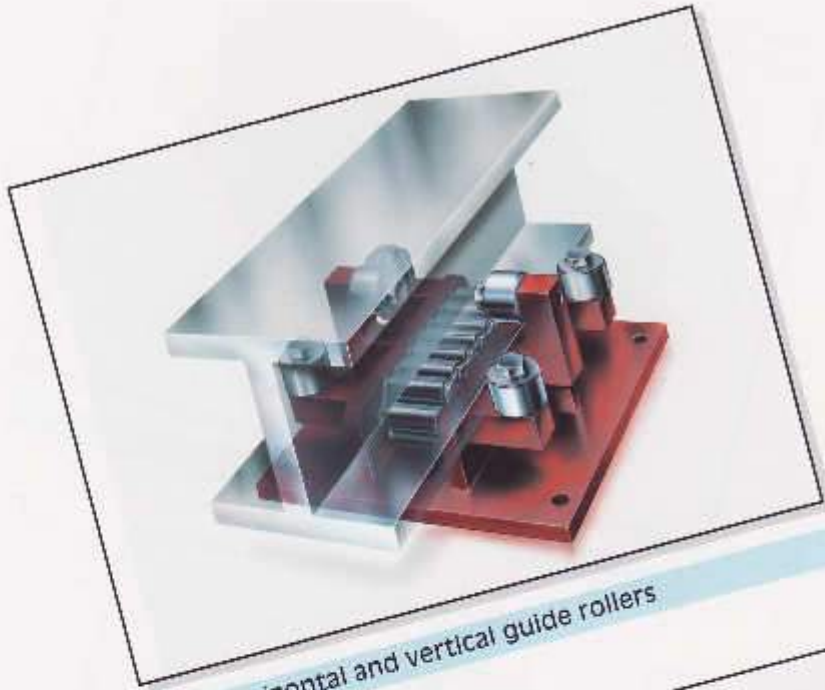

with horizontal and vertical guide rollers

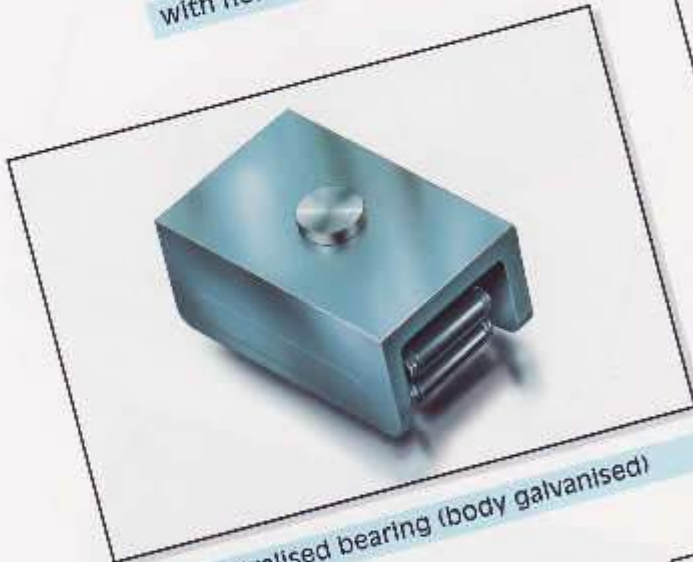

with centralised bearing (body galvanised)



according to drawing Sk 68 A



(galvanised) according to drawing 51-3-960



special construction acc. to drawing 51-3-1109

Roller Skates made to measure



according to drawing 51-5-1612

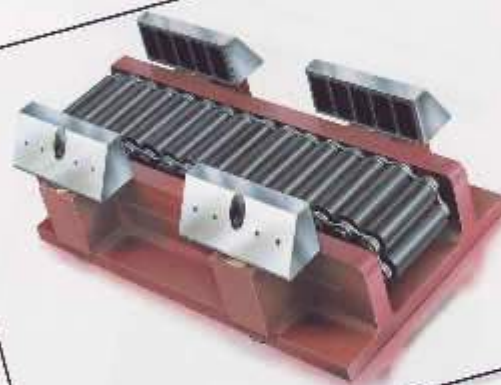

according to drawing 51-3-1407



according to drawing 51-3-1663



according to drawing 51-5-846



according to drawing 51-6-1721

Since 1951 our Rollers have been used in the following projects around the world (excerpts)

Germany

- since 1951 Uncounted moving of machine tools in the whole world
- 1955 Moved a complete house on 25 rollers to make way for a new canal between the North and Baltic Seas
- since 1955 Moving of large scaffold towers and shuttering for specialist companies e. bridge construction for motorway between Cologne and Hagen A1 and Cologne – Frankfurt
- 1957 Roller skates used to position bridge near Hamburg
- 1958 Moving a complete house to make room for a new road
- since 1958 100 tonnes hydraulic cylinders fitted with Roller Skates
- 1958 Bridge of Lultzhausen over the valley of Dirbach
- 1962 Used to build Listertal bridge near Lüdenscheid
- 1962 Removal and replacement of ship engines for repair purposes
- 1964 Used to assemble 30000 tonnes capacity hydraulic press
- since 1965 Used under high temperature conditions in the filling of furnaces
- since 1965 Use in bridge construction on the motorway between Dortmund and Frankfurt (Lennetalbrücke near Hagen, Kattenbusch near Lüdenscheid, bridge at Eisern, bridge over Siegtal, bridge over Landskroner Weiher
- since 1966 Several bridges near Bonn and in the southern part of motorway BAB 45
- since 1966 Transportation of containers on land and on ships
- since 1968 Underground railway in Cologne
- since 1970 Positioning of the Olympic Stadium roof in Munich
- 1972 Used in the construction of (nuclear) power stations
- since 1972 Support and guidance of test equipment in the mining industry
- 1973 / 1977 Used in the nuclear research project PETRA by DESY in Hamburg
- since 1975 Many Roller Skates used on NATO hardened aircraft shelter doors
- since 1975 Used in the repair of printing rollers in the printing industry
- 1975 Positioning of railway bridges at Meppen and Ratingen
- 1977 Used for bridge over Kochertal near Gelsingen
- since 1978 Used in coil and large tube production
- 1978 / 1979 Bridge construction over moor near Plön/Holstein
- 1979 For crane tower in German iron and steel works
- 1981 Bridge construction over the Löwental near Friedrichshafen
- 1981 For loading equipment for melting furnace
- 1982 Repositioning of complete furnace (> 1000 tonnes)
- 1983 Set of heavy duty wheels used for construction of underground railway near Nuremberg
- 1983 Bridge on B 61 near Bleiefeld
- 1984 Used for transportation of slag wagon in coke production
- 1984 Used for positioning counterbalance of cranes
- since 1986 Used on the construction of several tunnels for the German High Speed Railway
- 1986 Construction of bridge over the Danube near Regensburg
- since 1986 Bearing for heat expansion for paint spraying installations
- 1986 / 1987 Railway bridge at Oelde (Wareндorfer Str.)
- 1987 Used on big machine tools in the car industry
- 1988 Bridge over the motorway BAB 1 at Hagen
- 1988 Used in the nuclear research project ZEUS by DESY in Hamburg (3600 tonnes)
- 1989 Used in the nuclear research project HERA by DESY in Hamburg (3600 tonnes)
- 1991 Renovation of Weser Stadium in Bremen
- 1992 Positioning of scaffolds for railway overpass near Bad Kreuznach
- 1995 Used for extension of suburban railway of Stuttgart
- 1996 Used for bridge over the Saale at Schkortleben
- 1996 Used at Potsdamer Platz/Berlin
- 1997 For tunnels and bridges of the motorway BAB A 100

Germany

- 1997 Used in the transfer of road B 311 at Ertingen
- 1997 Used for extension of suburban railway at Braunschweig
- 1997 Road bridge B 69 at Bad Essen
- 1998 Used for tunnel constructions in Berlin
- 1999 Extension of suspension railway at Wuppertal
- 1999 Extension of Northern ramp of Elbtunnel near Hamburg
- 1999 For new construction of Grünbrücke B 464 (bridge)
- 1999 For renovation of bridges on motorway A 45 Dortmund – Frankfurt
- 2000 Tunnel near Ingolstadt
- 2000 Bridge over the Spree
- 2000 Tunnel on the banks of the river Weser near Porta Westfalica
- since 2000 Making movable a spectators' stand at the Arena at Schalke
- 2000 Railway bridge near Duisburg
- 2000 Tunnel under the Rhine for motorway A 44 near Iiverich
- 2002 Bridge over valley near Kaiserslautern
- 2002 Bridge over the Recknitz
- 2002 Twin roller skates for elimination of the movement of heeling over of a ship, which leaves the dock
- 2004 Multi function arena at Dusseldorf
- 2004 Tunnel Löwentor near Stuttgart

Austria

- since 1965 Used in bridge construction Europabrücke near Innsbruck and as well as bridges on the Brenner Motorway
- 1967 Viaducts and bridges on the motorway between Villach and Klagenfurt
- 1978 Railway bridge at Braunau/Inn
- 1995 Tunnel construction near Semmering
- 2005 / 2006 Renovation of bridges/tunnels on the Tauern motorway

France

- 1958 Construction of suspension bridge at Roche-Bernard/Bretagne
- since 1963 Renovation and expansion of Metro at Paris
- since 1964 Used on tunnelling machines during the construction of the R.E.R. network at Paris and suburbs
- 1965 To position a complete spectators' stand at the Longchamps racecourse (18000 tonnes)
- since 1965 Movement of heavy nuclear parts in nuclear power stations
- 1966 Construction of bridge to isle of Oleron
- 1967 Positioning of complete bridge between Ile de la Cité and Ile St Louis in Paris
- since 1967 Bridge construction on the motorway Nice – Mentone
- since 1969 Used on slipways to launch ships at Saint Nazaire
- since 1970 Used in the construction of the Mont Blanc tunnels
- 1971 Flyover bridge to the Isle of Noirmoutier
- 1971 For loading reactor parts (575 tonnes) on board of ships for a refinery
- 1972 Used in the foundation work for the Palace of Congress in Paris (Porte Maillot)
- 1974 Participation in suspension bridge near Saint Nazaire
- 1984 Roller skates equipped with hydraulics for off-shore platform
- 1985 Construction of the Eurotunnel
- since 1989 Construction of tunnels/bridges for the high speed railway (TGV) in France
- 1991 For construction of suspension bridge Pont de Normandie
- 1991 Construction of tunnel at Marseille
- 1991 Funicular railway at Tignes
- 1992 / 1993 Transportation of statues during renovation of Louvre in Paris
- 1998 Wheel sets for heavy press for plastics
- 1999 First equipment of glass ovens
- 2004 / 2006 First equipment of glass ovens

Projects around the world (excerpts)

Switzerland

- since 1955 Used on the first ring at CERN/Geneva nuclear research project
- since 1958 CERN has placed its electromagnets permanently on our roller skates
 - 1960 Twin roller skates for transporting transformers
- since 1978 Transportation of 240 tonnes stator for power station
- since 1981 Used in nuclear research project L3 at CERN/Geneva
 - 1982 Used on slipways in shipyard at Brienzensee
- 1983/1984 Restoration of Quaibrücke at Zurich
 - 1988 Moving of large transformers for repair in power stations
 - 1998 For Wititunnel
 - 1998 For tunnel Lüsslingen
- since 2004 New tunnel Alpentransversale in Tessin
 - 2004 Experiment LHCb at CERN/Geneva

Belgium/Luxemburg

- 1971 Part of a ship elevator near Waterloo
- since 1976 Specially designed roller skates used in the construction of a nuclear power station
 - 1980 Used during construction and installation of a new blast-furnace

Netherlands

- 1968 Repositioning of canal bridge near Vianen
- since 1971 Incorporated in the tooling for a large tube bending machine
- since 1973 To overcome problems during transportation of heavy loads in shipyards
- since 1976 Roller skates used for manoeuvring suction pipes on dredgers
 - 1993 Loading of an aeroplane with a 110 ton off-shore part
 - 1993 Positioning of 80 tonnes partitions on a container ship

Africa/Asia

- 1954/1955 Used during the construction of the Aswan Dam, Egypt
- since 1965 Construction of the Lower Volta bridge at Tema/Ghana
- since 1982 Bridge construction in Nigeria
 - 1983 Used by German construction company for positioning a heavy roof in Abu Dhabi
 - 1991 Thika-Dam in Kenya
 - 1993 Movement of winding tower (520 t) in China
 - 1993 Bridge construction in Nepal
 - 1995 For bridge construction in Thailand
 - 1996 For subway in China
 - 1997 For the Three Gorges Dam of the Yangtze River
 - 1998 For plant of spiral tube in Algeria
 - 1999 For My Thuan Bridge in Vietnam
 - 1999 For steel works at Bhilai/India
 - 2000 For a shipyard in Thailand
 - 2000 For demolition of Adam Road Flyover in Singapore
 - 2002 Displacement of a 4000 tonnes furnace in China
 - 2005 Launching complete railway bridges in Sri Lanka

Also distributed through the following:

All European countries – The Middle and Far East – Most African Countries – Asia and Australia – North America and most countries in Middle and South America

Scandinavia/Great Britain

- since 1982 Used in the off-shore industry with admission from Det-Norske-Veritas
 - 1996 For Oeresundtunnel
 - 1996 For retaining wall in Denmark
 - 1997 Bridge over and tunnel under the Great Belt
 - 1999 Tunnel Södra Länken in Sweden
 - 2003 For military airport in Great Britain

Eastern Europe

- 1978 Moscow airport
- 1979/1980 Olympic games, Moscow
 - 2000 Bridge over the Weichsel
 - 2004 Steel mill car equipment for rotation purposes in Kasachstan
 - 2005 Refinery in Belarus
 - 2005 Bridge D8 Tmice
 - 2005 Motorway construction near Köröshegy/Hungary

Southern Europe: Italy/Spain/Portugal

- since 1967 In the construction of bridges and viaducts on the Brenner Motorway
 - 1969 Specially designed rollers for a steel plant at Bilbao
 - Construction of bridges in the Palermo area
- 1970/1971 Bridge construction near Palermo
 - 1973 Bridge construction in Portugal
 - 1982 Twin roller skates for transporting transformers
 - 1987 Railway bridge over the Douro, Portugal
 - 1997 Vasco-da-Gama-bridge over the Tejo at Lisbon

America

- 1966 Roller skates used in ships construction in Peru
- since 1973 Specially designed roller skates for steel plant in Brazil
- since 1988 Movement of the space launching pad for the ARIANE
 - 1998 For Milwaukee Art Museum
 - 1998 For bridge building in Costa Rica
 - 2000 For 1000 tonnes Goliath crane
 - 2002 For bloom melting equipment at Cosipa in Brasil

Australia

- 1975 Used in a vertical position on a tower crane built in Germany for Australian customers

History of Börkey GmbH

- Foundation: 1945 GmbH since 1980
- Beginning of production of Roller Skates Express: 1951
- Beginning of production of Heavy Duty Wheels: 1955
- New plant on 4500 square metres ground since 1973
- New further production area: 1997

Heavy Duty Wheels

Wheels (without castors) – Drawing No. R1

Range of application:

- For robust use eg on construction sites.
- Can be inserted as a machine part.
- For transporting loads at a maximum speed of 100 m/min.
- When higher carrying capacity and greater sturdiness is required.
- Impervious to shavings and dust.

Characteristics of the model ...S with the greatest demand:

- Solid basic construction with ball bearings.
- Delivered with various castors.
- Made in stainless-steel on request.
- Special construction to suit customer requirements.
- Passed the DIN 4422 test at the material research laboratory for steel wheel 150 S.

Hints on use:

- Maintenance-free construction, used particularly in machine factories, on construction sites and for the handling of heavy goods.
- Can be combined with fixed castors and swivel castors (SF, SL, SD).

Model S



- Material with a high carrying capacity, which is not very susceptible to rough handling.
- When a higher carrying capacity is required, they can be fitted with self-aligning roller bearings (see model ... S/P).
- Can also be delivered as a flange wheel construction (see model S-A, S-B).
- If there are problems with friction it can also be delivered with convex crowned wheel running surface (without additional charge).
- The chosen bearing dictates the maximum carrying capacity of these wheels.

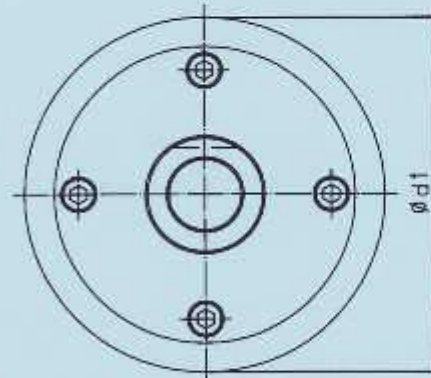
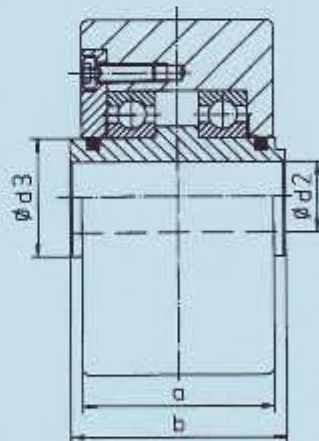

Model S

| Mod. | a | b | $\varnothing d1$ | $\varnothing d2$ | $\varnothing d3$ | Suitable castors | | | Carrying capacity (kN) | Weight (kg) |
|---------|----|----|------------------|------------------|------------------|------------------|----|----|------------------------|-------------|
| acciaio | | | | | | | | | | |
| 150 S | 80 | 90 | 150 | 30 | 50 | SF | SL | SD | 30 | 9.7 |
| 175 S | 80 | 90 | 175 | 30 | 50 | SF | SL | SD | 30 | 13.6 |
| 200 S | 80 | 90 | 200 | 30 | 50 | SF | SL | SD | 30 | 18.1 |
| 225 S | 80 | 90 | 225 | 30 | 50 | SF | | SD | 30 | 23.3 |
| 250 S | 80 | 90 | 250 | 30 | 50 | SF | | SD | 35 | 29.3 |
| 275 S | 80 | 90 | 275 | 30 | 50 | SF | | SD | 35 | 36.3 |
| 300 S | 80 | 90 | 300 | 30 | 50 | SF | | | 35 | 44.4 |

Heavy Duty Wheels

Model K, G



Range of application:

- Used in areas threatened by corrosion.
- For a particularly quiet running, which doesn't damage the ground.
- When lower carrying capacity and sturdiness lower than steel is required.
- In cases of minimal electric conductivity (plastic).
- For transporting loads at a maximum speed of 100 m/min.

Characteristics of the models ...K and ...G:

- Solid basic construction with ball bearings.
- Delivered with various mountings.
- Special construction to suit customer requirements.
- Passed the DIN 4422 test at the material research laboratory for plastic wheel 150 K.

■ Wheels (without castors) – Drawing No. R2



Hints on use:

- Construction free of maintenance with advantages over the steel wheel particularly in maritime environments or where is danger of corrosion.
- Can be combined with fixed castors and swivel castors.
- Material doesn't damage the ground, but is more susceptible than steel when handled roughly.

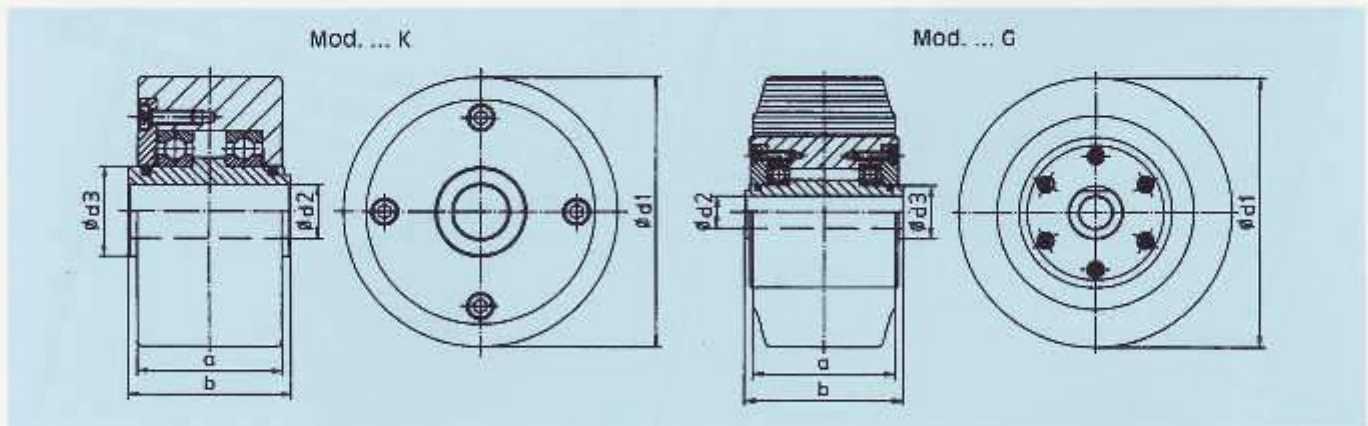

Model K, G

| Mod. | | a | b | Ø d1 | Ø d2 | Ø d3 | Suitable castors | | | Carrying capacity (kN) | | Weight (kg) | |
|---------|--------|-----|-----|------|------|------|------------------|----|----|------------------------|----|-------------|------|
| Plastic | Rubber | | | | | | SF | SL | SD | K | G | K | G |
| 150 K | | 80 | 90 | 150 | 30 | 50 | SF | SL | SD | 20 | | 3.7 | |
| 175 K | | 80 | 90 | 175 | 30 | 50 | SF | SL | SD | 20 | | 4.3 | |
| 200 K | | 80 | 90 | 200 | 30 | 50 | SF | SL | SD | 30 | | 5.0 | |
| 225 K | | 80 | 90 | 225 | 30 | 50 | SF | | SD | 30 | | 5.8 | |
| 250 K | | 80 | 90 | 250 | 30 | 50 | SF | | SD | 35 | | 6.7 | |
| | 250 G | 130 | 145 | 250 | 30 | 50 | SF | | SD | | 10 | | 9.0 |
| | 265 G | 160 | 175 | 265 | 30 | 50 | SF | | SD | | 15 | | 10.0 |
| 275 K | | 80 | 90 | 275 | 30 | 50 | SF | | SD | 35 | | 7.6 | |
| 300 K | | 80 | 90 | 300 | 30 | 50 | SF | | | 35 | | 8.7 | |

Heavy Duty Wheels

Model S/P



Characteristics of the model ... S/P:

- Solid steel construction with self-aligning roller bearings.
- Body hardened to 35-38 HRC with crowned wheel running surface.
- Delivered with various mountings as fixed castors and swivel castors (SF, SL, SD).

Wheels (without castors) – Drawing No. R3

Range of application:

- For robust use e.g. on construction sites.
- Can be inserted as a machine part.
- For transporting loads at a maximum speed of 100 m/min.
- When higher carrying capacity and greater sturdiness is required.
- When higher safety standards and heavy duty are required.

Hints on use:

- Maintenance-free construction, used particularly in machine factories, on construction sites and for the handling of heavy goods.
- Can be combined with fixed castors and swivel castors.
- Material with a high carrying capacity, which is not very susceptible to rough handling.
- Can also be delivered as a flange wheel construction (see model S-A/P; S-B/P).

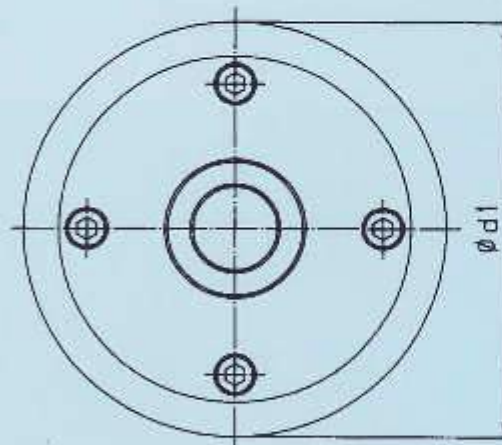
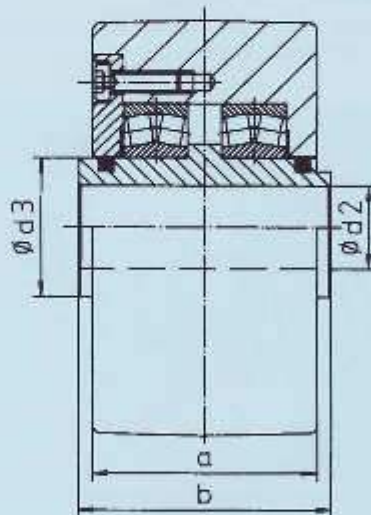

Model S/P

| Mod. | a | b | $\varnothing d1$ | $\varnothing d2$ | $\varnothing d3$ | | | | | | | suitable castors | Carrying capacity (kN) | Weight (kg) |
|---------|----|----|------------------|------------------|------------------|--|--|--|--|--|--|------------------|------------------------|-------------|
| Steel | | | | | | | | | | | | | | |
| 150 S/P | 80 | 90 | 150 | 30 | 50 | | | | | | | SF SL SD | 50 | 9.9 |
| 175 S/P | 80 | 90 | 175 | 30 | 50 | | | | | | | SF SL SD | 50 | 13.8 |
| 200 S/P | 80 | 90 | 200 | 30 | 50 | | | | | | | SF SL SD | 60 | 18.3 |
| 225 S/P | 80 | 90 | 225 | 30 | 50 | | | | | | | SF | 60 | 23.5 |
| 250 S/P | 80 | 90 | 250 | 30 | 50 | | | | | | | SF | 80 | 29.5 |
| 275 S/P | 80 | 90 | 275 | 30 | 50 | | | | | | | SF | 80 | 36.5 |
| 300 S/P | 80 | 90 | 300 | 30 | 50 | | | | | | | SF | 80 | 44.6 |

Heavy Duty Wheels

Wheels (without castors) – Drawing No. R4

Model S-A (B), S-A (B)/P

Range of application:

- For use on profiles (girders/rails).
- Can be inserted as a machine part.
- For transporting loads at a maximum speed of 100 m/min.
- With a flange wheel (= A) or with 2 flange wheels (= B).
- The maximum distance between 2 flange wheels $x = 55$ mm for the serial wheel.
- When choosing 2 flange wheels, please state the dimension x .



Characteristics of the model ... S and ... S/P:

- Solid steel construction with ball bearings (S) or self-aligning roller bearings (S/P).
- Delivered also as a fixed castor.
- Special construction to suit customer requirements.

Hints on use:

- Maintenance-free construction, used particularly in machine factories.
- Narrower distance between flange wheels if required, distances > 55 mm on request.
- Can be combined with fixed castors.
- Body of the wheel can be hardened (extra charge) but is standard with model ... S/P (without additional charge).

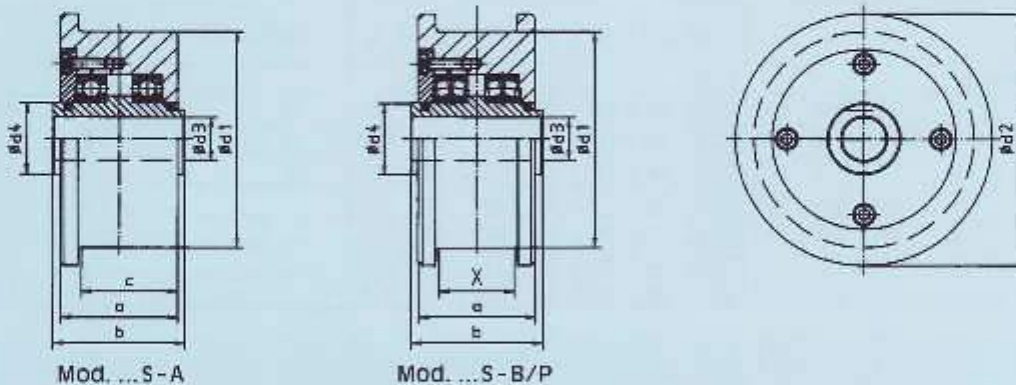

Model (Steel)

| Mod. | | a | b | c | Ø d1 | Ø d2 | Ø d3 | Ø d4 | X max. | Suitable castors | Carrying capacity (kN) | | Weight (kg) | |
|----------|-----------|----|----|------|------|------|------|------|--------|------------------|------------------------|------|-------------|--|
| 1 Flange | 2 Flanges | | | | | | | | | | | A | B | |
| 125 S-A | 125 S-B | 80 | 90 | 67.5 | 125 | 150 | 30 | 50 | 55 | SF ...S-A(B) | 20 | 7.5 | 7.9 | |
| 150 S-A | 150 S-B | 80 | 90 | 67.5 | 150 | 175 | 30 | 50 | 55 | SF ...S-A(B) | 25 | 10.2 | 10.7 | |
| 175 S-A | 175 S-B | 80 | 90 | 67.5 | 175 | 200 | 30 | 50 | 55 | SF ...S-A(B) | 30 | 14.1 | 14.7 | |
| 200 S-A | 200 S-B | 80 | 90 | 67.5 | 200 | 225 | 30 | 50 | 55 | SF ...S-A(B) | 30 | 18.7 | 19.4 | |

Model (Steel) .../P

| Mod. | | a | b | c | Ø d1 | Ø d2 | Ø d3 | Ø d4 | X max. | Suitable castors | Carrying capacity (kN) | | Weight (kg) | |
|-----------|-----------|----|----|------|------|------|------|------|--------|------------------|------------------------|------|-------------|--|
| 1 Flange | 2 Flanges | | | | | | | | | | | A | B | |
| 150 S-A/P | 150 S-B/P | 80 | 90 | 67.5 | 150 | 175 | 30 | 50 | 55 | SF ...S-A(B)/P | 40 | 10.4 | 10.9 | |
| 175 S-A/P | 175 S-B/P | 80 | 90 | 67.5 | 175 | 200 | 30 | 50 | 55 | SF ...S-A(B)/P | 40 | 14.3 | 14.9 | |
| 200 S-A/P | 200 S-B/P | 80 | 90 | 67.5 | 200 | 225 | 30 | 50 | 55 | SF ...S-A(B)/P | 50 | 18.9 | 19.6 | |
| 225 S-A/P | 225 S-B/P | 80 | 90 | 67.5 | 225 | 275 | 30 | 50 | 55 | SF ...S-A(B)/P | 50 | 24.3 | 25.1 | |
| 250 S-A/P | 250 S-B/P | 80 | 90 | 67.5 | 250 | 300 | 30 | 50 | 55 | SF ...S-A(B)/P | 65 | 30.3 | 31.1 | |

Heavy Duty Wheels

Model SF ... S, K, S/P

■ Fixed castors – Drawing No. R5

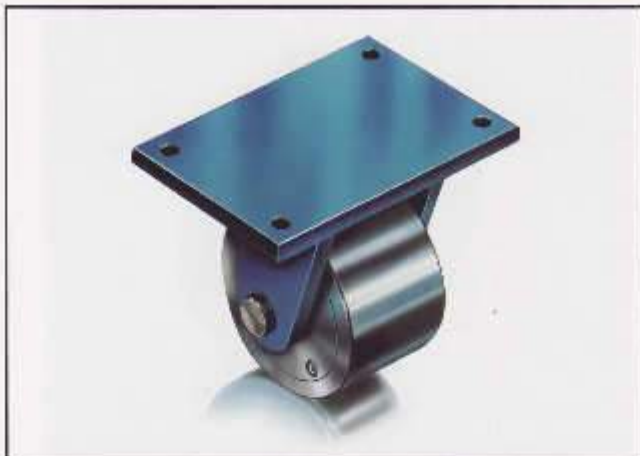

Range of application:

- For transporting loads at a maximum speed of 100 m/min.
- Flange wheels for use on profiles (see drawing No. R8).

Characteristics of the model ...SF ... S, K, S/P:

- Solid steel construction of the fixed castor.
- Position of fixing holes in top plate can be arranged to suit customers' requirement.
- Can be combined with other castors.
- Passed the DIN 4422 test at the material research laboratory for SF 150 S + SF 150 K.

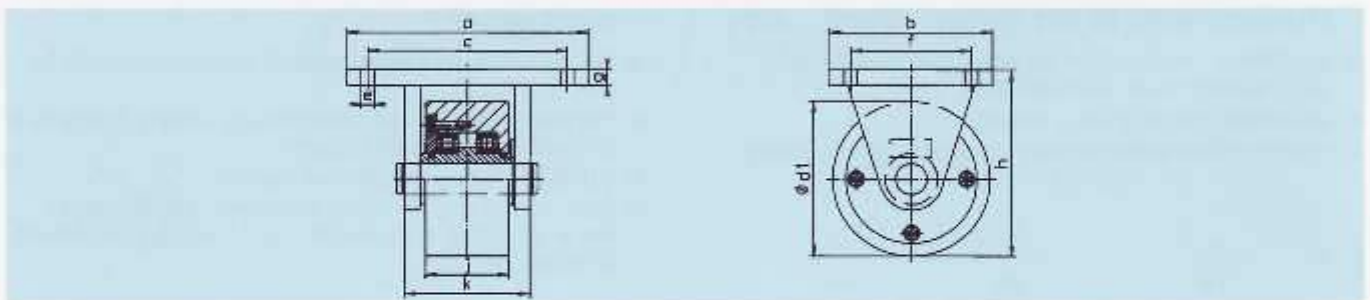

Model SF ... S, SF ... K

| Mod. | | a | b | c | Ø d1 | Ø e | f | g | h | j | k | Suitable castors | | Carrying capacity (kN) | | Weight (kg) | |
|----------|----------|-----|-----|-----|------|-----|-----|----|-----|----|-----|------------------|----|------------------------|----|-------------|------|
| Steel | Plastic | | | | | | | | | | | SL | SD | S | K | S | K |
| SF 150 S | SF 150 K | 220 | 150 | 190 | 150 | 14 | 115 | 15 | 180 | 80 | 120 | SL | SD | 30 | 20 | 16.7 | 10.7 |
| SF 175 S | SF 175 K | 220 | 150 | 190 | 175 | 14 | 115 | 15 | 210 | 80 | 120 | SL | SD | 30 | 20 | 21.4 | 12.1 |
| SF 200 S | SF 200 K | 220 | 150 | 190 | 200 | 14 | 115 | 15 | 235 | 80 | 120 | SL | SD | 30 | 30 | 26.7 | 13.6 |
| SF 225 S | SF 225 K | 220 | 150 | 190 | 225 | 14 | 115 | 15 | 260 | 80 | 120 | | | 30 | 30 | 32.7 | 15.2 |
| SF 250 S | SF 250 K | 270 | 210 | 210 | 250 | 18 | 150 | 15 | 285 | 80 | 120 | | | 35 | 35 | 41.9 | 19.3 |
| SF 275 S | SF 275 K | 270 | 210 | 210 | 275 | 18 | 150 | 15 | 310 | 80 | 120 | | | 35 | 35 | 49.7 | 21.0 |
| SF 300 S | SF 300 K | 270 | 210 | 210 | 300 | 18 | 150 | 15 | 335 | 80 | 120 | | | 35 | 35 | 58.6 | 22.9 |

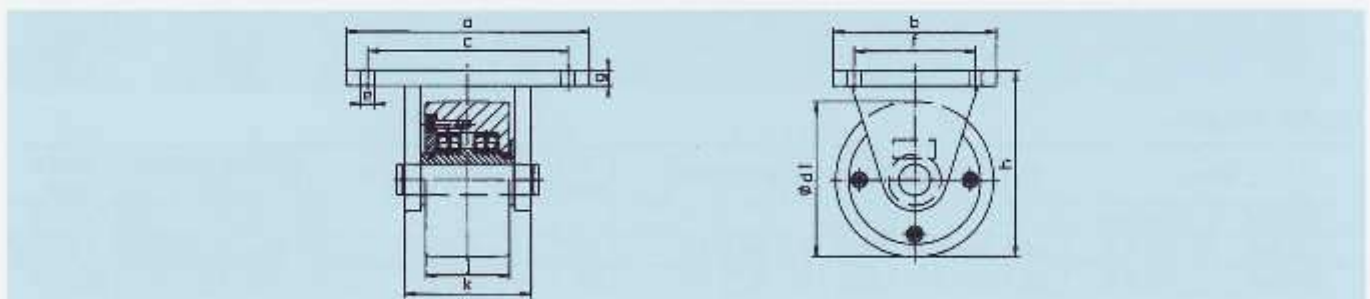

Model SF ... S/P

| Mod. | | a | b | c | Ø d1 | Ø e | f | g | h | j | k | Suitable castors | | Carrying capacity (kN) | | Weight (kg) | |
|------------|--|-----|-----|-----|------|-----|-----|----|-----|----|-----|------------------|----|------------------------|--|-------------|------|
| Steel | | | | | | | | | | | | SL | SD | | | | |
| SF 150 S/P | | 220 | 170 | 180 | 150 | 18 | 130 | 20 | 195 | 80 | 130 | SL | SD | 50 | | | 16.9 |
| SF 175 S/P | | 220 | 170 | 180 | 175 | 18 | 130 | 20 | 220 | 80 | 130 | SL | SD | 50 | | | 21.6 |
| SF 200 S/P | | 220 | 170 | 180 | 200 | 18 | 130 | 20 | 245 | 80 | 130 | SL | SD | 60 | | | 26.9 |
| SF 225 S/P | | 220 | 170 | 180 | 225 | 18 | 130 | 20 | 285 | 80 | 130 | | | 60 | | | 32.9 |
| SF 250 S/P | | 270 | 210 | 210 | 250 | 18 | 160 | 20 | 310 | 80 | 130 | | | 80 | | | 42.1 |
| SF 275 S/P | | 270 | 210 | 210 | 275 | 18 | 160 | 20 | 320 | 80 | 130 | | | 80 | | | 49.9 |
| SF 300 S/P | | 270 | 210 | 210 | 300 | 18 | 160 | 20 | 345 | 80 | 130 | | | 80 | | | 58.8 |

Heavy Duty Wheels

■ Swivel castors – Drawing No. R6

Range of application:

- For transporting loads at a maximum speed of 100 m/min.
- For turning corners.

Characteristics of the model ... SL:

- Solid steel construction of the self-guided castor.
- Can be combined with other mountings.
- Passed the DIN 4422 test at the material research laboratory for SL 150 S + SL 150 K.

Model SL ... S, K, S/P

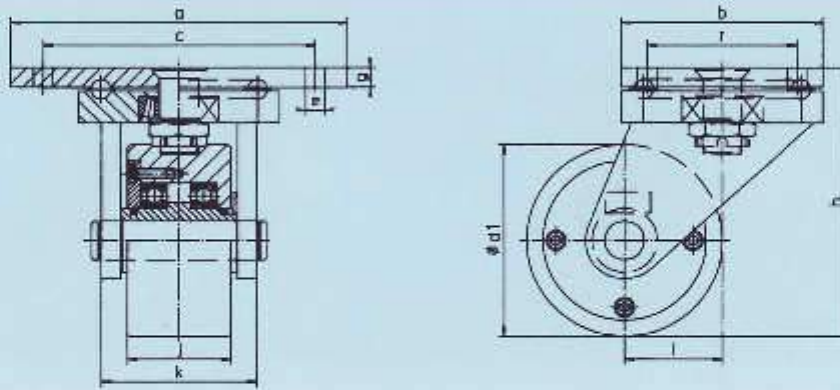

Model SL ... S, SL ... K

| Mod. | | a | b | c | Ø d1 | Ø e | f | g | h | j | k | Suitable castors | Carrying capacity (kN) | | Weight (kg) | |
|----------|----------|-----|-----|-----|------|-----|-----|----|-----|----|-----|------------------|------------------------|----|-------------|------|
| Steel | Plastic | | | | | | | | | | | | S | K | S | K |
| SL 150 S | SL 150 K | 270 | 150 | 210 | 150 | 18 | 115 | 15 | 210 | 80 | 120 | SF | 30 | 20 | 22.7 | 16.7 |
| SL 175 S | SL 175 K | 270 | 150 | 210 | 175 | 18 | 115 | 15 | 235 | 80 | 120 | SF | 30 | 20 | 27.5 | 18.2 |
| SL 200 S | SL 200 K | 270 | 150 | 210 | 200 | 18 | 115 | 15 | 260 | 80 | 120 | SF | 30 | 30 | 32.9 | 19.8 |

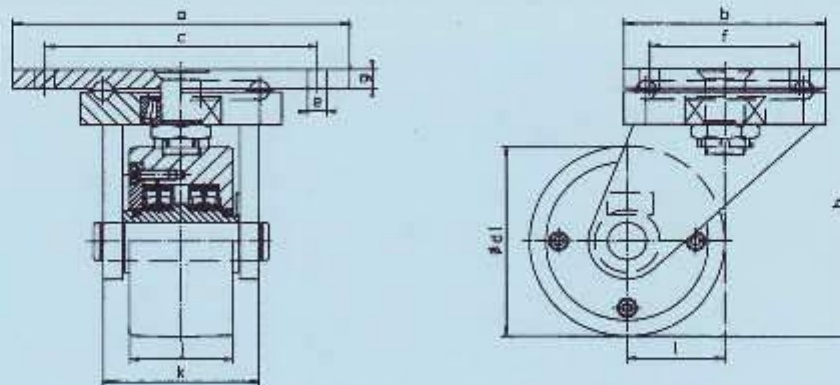

Model SL ... S/P

| Mod. | | a | b | c | Ø d1 | Ø e | f | g | h | j | k | Suitable castors | Carrying capacity (kN) | | Weight (kg) |
|------------|--|-----|-----|-----|------|-----|-----|----|-----|----|-----|------------------|------------------------|--|-------------|
| Steel | | | | | | | | | | | | | | | |
| SL 150 S/P | | 270 | 170 | 220 | 150 | 18 | 130 | 20 | 220 | 80 | 130 | SF | 50 | | 22.9 |
| SL 175 S/P | | 270 | 170 | 220 | 175 | 18 | 130 | 20 | 245 | 80 | 130 | SF | 50 | | 27.7 |
| SL 200 S/P | | 270 | 170 | 220 | 200 | 18 | 130 | 20 | 285 | 80 | 130 | SF | 60 | | 33.1 |

Heavy Duty Wheels

Model SD ... S, K, S/P

■ Swivel castors – Drawing No. R7



Range of application:

- For transporting loads at a maximum speed of 100 m/min.
- For turning corners.
- Frequently used on construction sites.

Characteristics of the model ... SD:

- Solid steel construction of the rotating mountings.
- Can be combined with other castors.

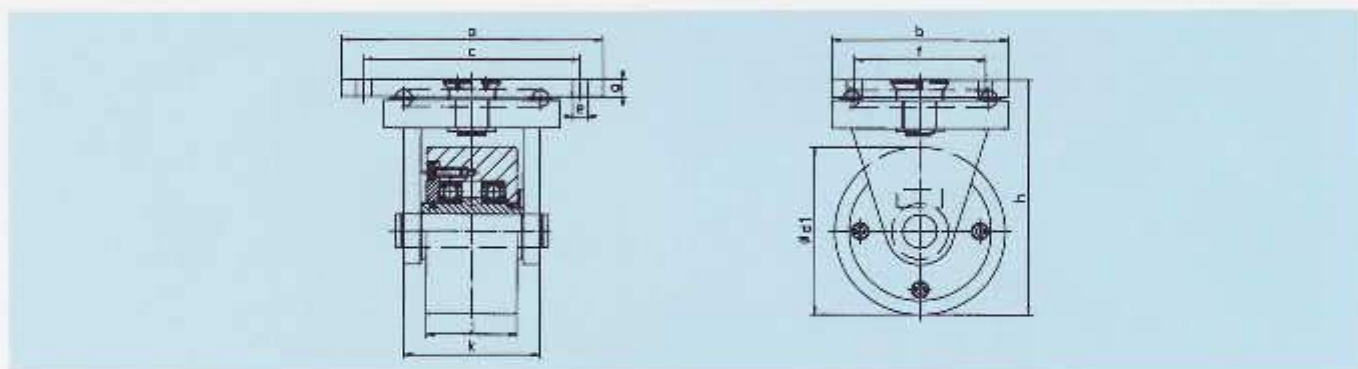

Model SD ... S, SD ... K

| Mod. | | a | b | c | Ø d1 | Ø e | f | g | h | j | k | Suitable castors | Carrying capacity (kN) | | Weight (kg) | |
|----------|----------|-----|-----|-----|------|-----|-----|----|-----|----|-----|------------------|------------------------|----|-------------|------|
| Steel | Plastic | | | | | | | | | | | | S | K | S | K |
| SD 150 S | SD 150 K | 220 | 150 | 190 | 150 | 14 | 115 | 15 | 210 | 80 | 120 | SF | 30 | 20 | 21.4 | 15.4 |
| SD 175 S | SD 175 K | 220 | 150 | 190 | 175 | 14 | 115 | 15 | 235 | 80 | 120 | SF | 30 | 20 | 26.2 | 16.9 |
| SD 200 S | SD 200 K | 220 | 150 | 190 | 200 | 14 | 115 | 15 | 260 | 80 | 120 | SF | 30 | 30 | 31.6 | 18.5 |
| SD 225 S | SD 225 K | 270 | 210 | 210 | 225 | 18 | 150 | 15 | 285 | 80 | 120 | SF | 30 | 30 | 40.4 | 22.9 |
| SD 250 S | SD 250 K | 270 | 210 | 210 | 250 | 18 | 150 | 15 | 310 | 80 | 120 | SF | 35 | 35 | 47.3 | 24.7 |
| SD 275 S | SD 275 K | 270 | 210 | 210 | 275 | 18 | 150 | 15 | 335 | 80 | 120 | SF | 35 | 35 | 55.2 | 26.5 |

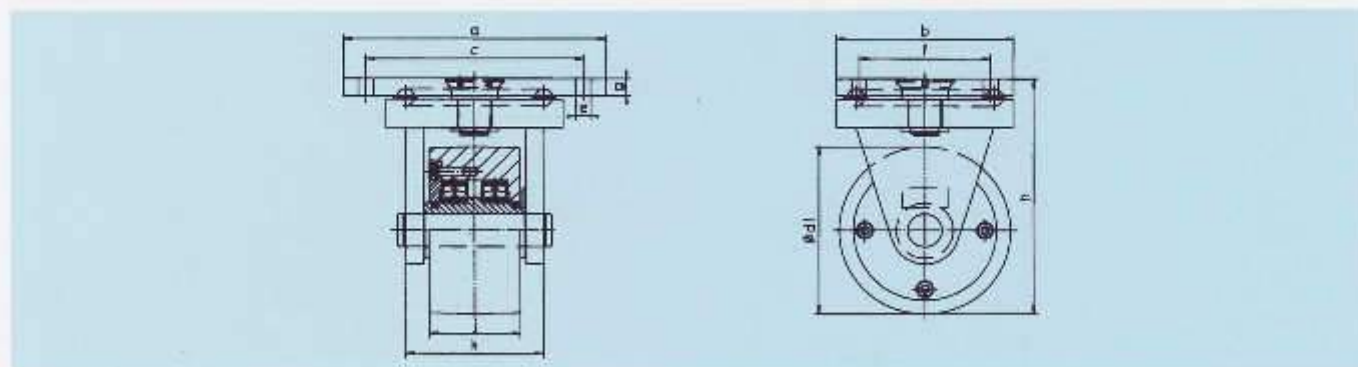

Model SD ... S/P

| Mod. | | a | b | c | Ø d1 | Ø e | f | g | h | j | k | Suitable castors | Carrying capacity (kN) | | Weight (kg) | |
|------------|--|-----|-----|-----|------|-----|-----|----|-----|----|-----|------------------|------------------------|--|-------------|------|
| Steel | | | | | | | | | | | | | | | | |
| SD 150 S/P | | 270 | 170 | 220 | 150 | 18 | 130 | 20 | 220 | 80 | 130 | SF | 50 | | | 21.6 |
| SD 175 S/P | | 270 | 170 | 220 | 175 | 18 | 130 | 20 | 245 | 80 | 130 | SF | 50 | | | 26.4 |
| SD 200 S/P | | 270 | 170 | 220 | 200 | 18 | 130 | 20 | 285 | 80 | 130 | SF | 60 | | | 31.8 |

Heavy Duty Wheels

■ Flange wheels with fixed castors - Drawing No. R8

Range of application:

- For transporting loads at a maximum speed of 100 m/min.
- Flange wheels for use on profiles.
- Frequently used on construction sites.
- Frequent use in machine factories.

Characteristics of the model ...SF ...S-A, SF ...S-A/P:

- Solid steel construction for fixed castors.
- Position of fixing holes in top plate can be arranged to suit customers' requirements.

Model SF ...S-A (B), S-A (B)/P

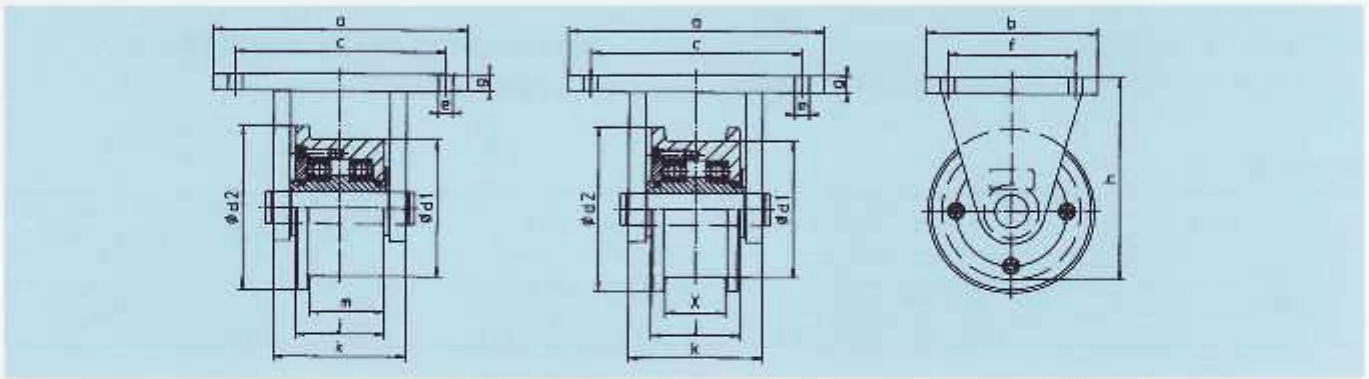
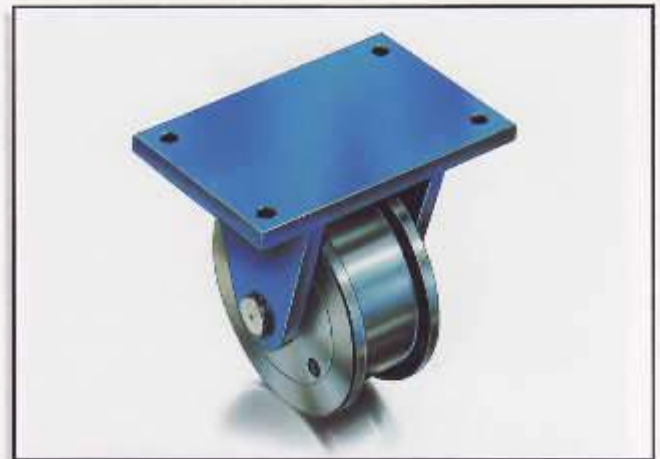

Model SF ...S-A(B)

| Mod. | | a | b | c | Ø d1 | Ø d2 | Ø e | f | g | h | j | k | m | x max | Suitable castors | Carrying capacity (kN) | Weight (kg) | |
|------------|------------|-----|-----|-----|------|------|-----|-----|----|-----|----|-----|------|-------|------------------|------------------------|-------------|------|
| 1 Flange | 2 Flanges | | | | | | | | | | | | | | | A | B | |
| SF 125 S-A | SF 125 S-B | 220 | 150 | 190 | 125 | 150 | 14 | 115 | 15 | 180 | 80 | 120 | 67.5 | 55 | SF | 20 | 14.5 | 14.9 |
| SF 150 S-A | SF 150 S-B | 220 | 150 | 190 | 150 | 175 | 14 | 115 | 15 | 210 | 80 | 120 | 67.5 | 55 | SF | 25 | 17.2 | 17.7 |
| SF 175 S-A | SF 175 S-B | 220 | 150 | 190 | 175 | 200 | 14 | 115 | 15 | 235 | 80 | 120 | 67.5 | 55 | SF | 30 | 21.9 | 22.5 |
| SF 200 S-A | SF 200 S-B | 220 | 150 | 190 | 200 | 225 | 14 | 115 | 15 | 260 | 80 | 120 | 67.5 | 55 | SF | 30 | 27.3 | 28.0 |

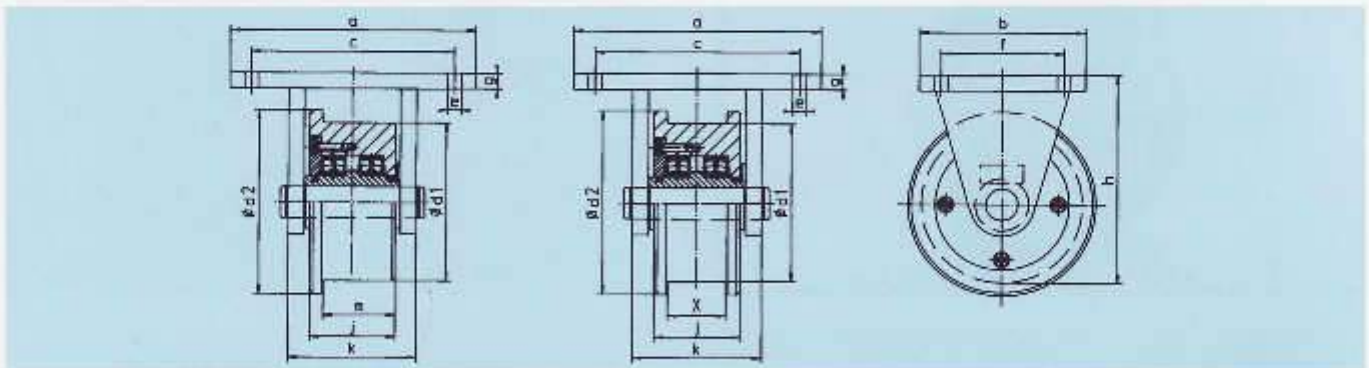

Model SF ...S-A(B)/P

| Mod. | | a | b | c | Ø d1 | Ø d2 | Ø e | f | g | h | j | k | m | x max | Suitable castors | Carrying capacity (kN) | Weight (kg) | |
|--------------|--------------|-----|-----|-----|------|------|-----|-----|----|-----|----|-----|------|-------|------------------|------------------------|-------------|------|
| 1 Flange | 2 Flanges | | | | | | | | | | | | | | | A | B | |
| SF 150 S-A/P | SF 150 S-B/P | 220 | 170 | 180 | 150 | 175 | 18 | 130 | 20 | 195 | 80 | 130 | 67.5 | 55 | SF | 40 | 17.4 | 17.9 |
| SF 175 S-A/P | SF 175 S-B/P | 220 | 170 | 180 | 175 | 200 | 18 | 130 | 20 | 220 | 80 | 130 | 67.5 | 55 | SF | 40 | 22.1 | 22.7 |
| SF 200 S-A/P | SF 200 S-B/P | 220 | 170 | 180 | 200 | 225 | 18 | 130 | 20 | 245 | 80 | 130 | 67.5 | 55 | SF | 50 | 27.5 | 28.2 |
| SF 225 S-A/P | SF 225 S-B/P | 220 | 170 | 180 | 225 | 275 | 18 | 130 | 20 | 285 | 80 | 130 | 67.5 | 55 | SF | 50 | 33.7 | 34.5 |
| SF 250 S-A/P | SF 250 S-B/P | 270 | 210 | 210 | 250 | 300 | 18 | 160 | 20 | 310 | 80 | 130 | 67.5 | 55 | SF | 65 | 42.9 | 43.7 |

Heavy Duty Wheels

Model SF ... G

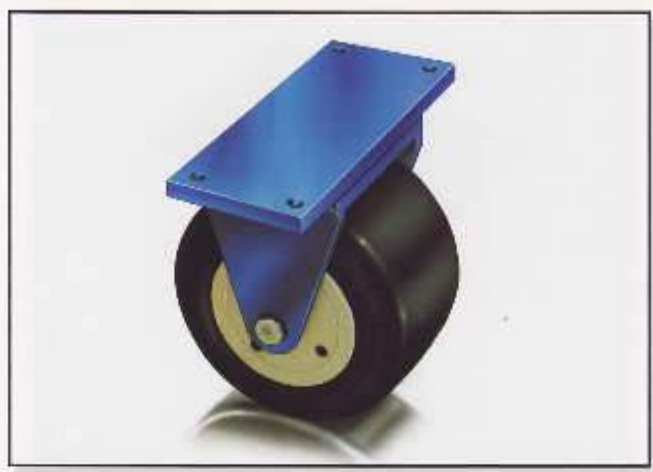

Range of application:
 ■ For quiet running, which doesn't damage the ground.

Model SF ... G

| Mod. | a | b | c | Ø d1 | Ø e | f | g | h | j | k | Suitable castors | Carrying capacity (kN) | Weight (kg) |
|----------|-----|-----|-----|------|-----|-----|----|-----|-----|-----|------------------|------------------------|-------------|
| Rubber | | | | | | | | | | | | | |
| SF 250 G | 300 | 150 | 260 | 250 | 14 | 115 | 15 | 330 | 130 | 175 | SD | 10 | 23.0 |
| SF 265 G | 300 | 150 | 260 | 265 | 14 | 115 | 15 | 345 | 160 | 205 | SD | 15 | 25.0 |

Model SD ... G



Range of application:
 ■ For quiet running, which doesn't damage the ground.

Model SD ... G

| Mod. | a | b | c | Ø d1 | Ø e | f | g | h | j | k | Suitable castors | Carrying capacity (kN) | Weight (kg) |
|----------|-----|-----|-----|------|-----|-----|----|-----|-----|-----|------------------|------------------------|-------------|
| Rubber | | | | | | | | | | | | | |
| SD 250 G | 300 | 150 | 260 | 250 | 14 | 115 | 15 | 330 | 130 | 175 | SF | 10 | 29.0 |
| SD 265 G | 300 | 150 | 260 | 265 | 14 | 115 | 15 | 345 | 160 | 205 | SF | 15 | 31.0 |

■ Fixed castors – Drawing No. R9

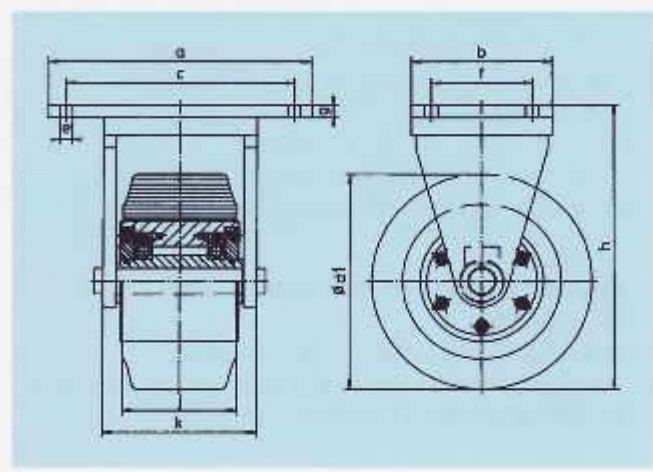

Characteristics of the model SF ... G:
 ■ Fixed castor with rubber tyre.

■ Guidable swivel rollers – Drawing No. R10

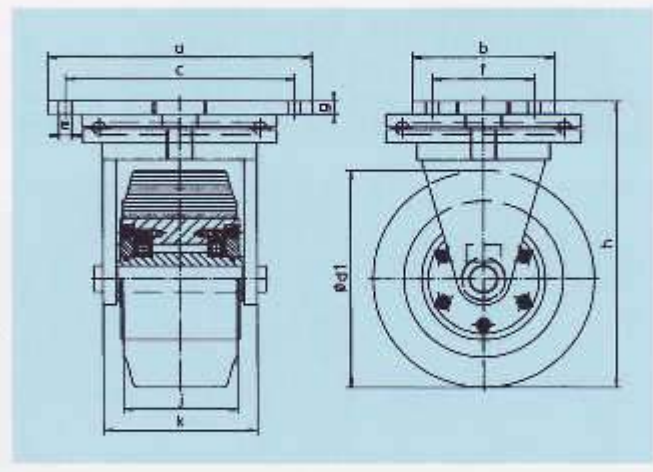

Characteristics of the model SD ... G:
 ■ Swivel castor with rubber tyre.

Heavy Duty Wheels

■ Sets of wheels – Drawing No. R11



Model WRS



Range of application:

- Less integral floor pressure than with the Roller Skate Express.
- If the running surface is very uneven.
- Delivered according to individual customer's requirements and according to the assigned requirements of the product.

Characteristics of the model ... WRS:

- Solid steel construction with
 - Grooved bearings (single or double row) (WRS ... -RK), or
 - Self-aligning roller bearing (WRS ... -PR), or
 - Tapered-roller bearing (clearance adjustable) (WRS ... -KP)
- Hardened wheel bodies, various types of steel (C45, CrNi, CrMo) depending on customers requirements

Hints on use:

- Maintenance-free construction, used particularly on wharfs and at airports.
- Problems solved for individual customers.
- Material with a high carrying capacity: individual carrying capacity up to 1.000 kN.
- Small single units are also produced.
- Maximum speed: 100 m/min.

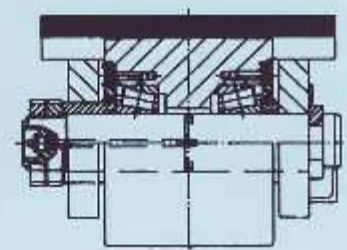
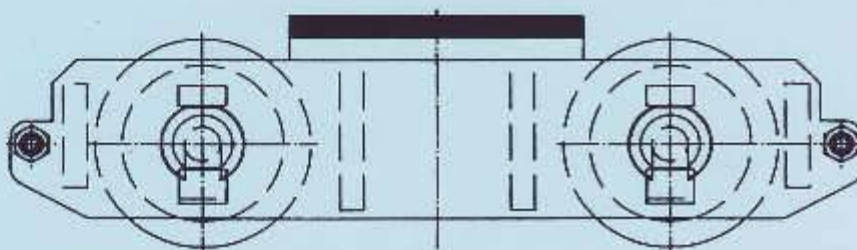

The original: made in Germany since 1951



Inventor of
Roller Skates

Projects (selection)



Further details on page 25 and 26

