

▼ Shown from left to right: RAC-508, RAC-1506, RAC-304, and RAC-206



Lightweight for Maximum Portability



Saddles

All RAC cylinders are equipped with bolt-on removable saddles of hardened steel.



Lightweight Hand Pumps

Enerpac hand pumps **P-392** or **P-802** make the optimal lightweight set.

Page: **70**

- Composite bearings prevent metal-to-metal contact, increasing cylinder life and resistance to side-loads of up to 10%
- Hard coat finish on all surfaces resists damage and extends cylinder life
- Handles included on all models 30 tons and above
- For protection against load-induced damage, a saddle is standard on all models and a steel baseplate is standard on models 20-ton and above. The steel baseplate is optional only on 10- and 15-ton models
- Integral stop ring prevents plunger over-travel and is capable of withstanding the full cylinder capacity
- High-strength return spring for rapid cylinder retraction
- CR-400 coupler and dust cap included on all models
- All cylinders meet ASME B-30.1 standards

Cylinder Capacity tons (maximum)	Stroke* (in)	Model Number	Cylinder Effective Area (in ²)
10 (9.9)	1.97	RAC-102	1.95
	3.94	RAC-104	1.95
	5.91	RAC-106	1.95
15 (15.4)	1.97	RAC-152	3.03
	3.94	RAC-154	3.03
	5.91	RAC-156	3.03
20 (24.2)	1.97	RAC-202	4.83
	3.94	RAC-204	4.83
	5.91	RAC-206	4.83
	7.87	RAC-208	4.83
	9.84	RAC-2010	4.83
30 (34.2)	1.97	RAC-302	6.85
	3.94	RAC-304	6.85
	5.91	RAC-306	6.85
	7.87	RAC-308	6.85
	9.84	RAC-3010	6.85
50 (54.9)	1.97	RAC-502	10.99
	3.94	RAC-504	10.99
	5.91	RAC-506	10.99
	7.87	RAC-508	10.99
	9.84	RAC-5010	10.99
100 (110.9)	1.97	RAC-1002	22.19
	3.94	RAC-1004	22.19
	5.91	RAC-1006	22.19
	7.87	RAC-1008	22.19
	9.84	RAC-10010	22.19
150 (175.9)	1.97	RAC-1502	35.18
	3.94	RAC-1504	35.18
	5.91	RAC-1506	35.18
	7.87	RAC-1508	35.18
	9.84	RAC-15010	35.18

* Custom strokes available.



◀ Enerpac lightweight aluminum RAC-506 cylinders are ideal for wet environments such as this tunnel under the river (Holland High-Speed Train Line).

Single-Acting, Spring Return Cylinders



Steel Base Plate

The steel base plate protects the cylinder base from damage, it should not be removed.

The base holes in these aluminum cylinders are designed for securing the steel base plate. **They will not withstand the capacity of the cylinder.**

Do not use the base holes in these aluminum cylinders to attach any device to the cylinder.

Capacity:
10-150 tons

Stroke:
1.97-9.84 inches

Maximum Operating Pressure:
10,000 psi

RAC Series



Optional Bolt-on Tilt Saddle Dimensions (in)

Cylinder Model / Capacity (ton)	Model Number*	Saddle Diameter J1	Saddle Protrusion from Plunger K1
RAC-50	CATG-50	1.95	1.02
RAC-100	CATG-150	3.57	1.30
RAC-150	CATG-200	4.64	1.44

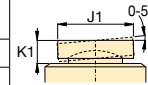

* Tilt saddle not available for less than 50 ton.

Optional Steel Base Plate

Cylinder Model / Capacity (ton)	Model Number
RAC-10	JBA10
RAC-15	JBA15

* Steel base plates come standard on models 20 tons and above.

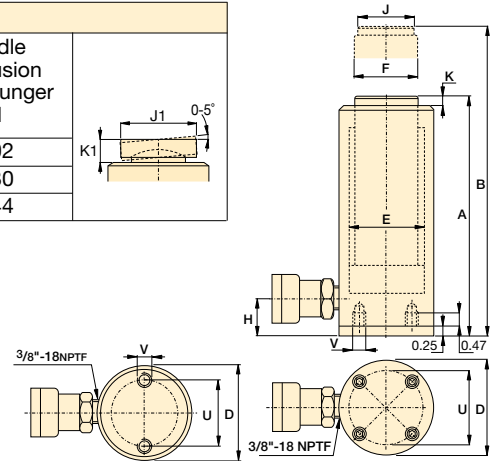

RAC-102 to RAC-156 RAC-202 to RAC-15010

Oil Capacity (in ³)	Collapsed Height A (in)	Extended Height B (in)	Outside Diameter D (in)	Cylinder Bore Diameter E (in)	Plunger Diameter F (in)	Base to Advance Port H (in)	Saddle Diameter J (in)	Saddle Protrusion from Plunger K (in)	Bolt Circle U (in)	Thread V (mm)	Weight (lbs)	Model Number
3.66	6.06	7.91	2.28	1.57	1.26	0.91	0.94	0.12	1.54	M6	2.6	RAC-102
7.93	8.03	11.97	2.28	1.57	1.26	0.91	0.94	0.12	1.54	M6	3.1	RAC-104
11.59	10.00	15.91	2.28	1.57	1.26	0.91	0.94	0.12	1.54	M6	4.0	RAC-106
6.10	6.34	8.31	2.76	1.97	1.57	0.91	1.14	0.12	1.89	M6	4.0	RAC-152
12.20	8.31	12.24	2.76	1.97	1.57	0.91	1.14	0.12	1.89	M6	4.2	RAC-154
17.69	10.28	16.18	2.76	1.97	1.57	0.91	1.14	0.12	1.89	M6	6.6	RAC-156
9.52	6.85	8.83	3.35	2.48	1.97	1.07	1.58	0.12	2.76	M6	7.9	RAC-202
19.03	8.82	12.76	3.35	2.48	1.97	1.07	1.58	0.12	2.76	M6	9.0	RAC-204
28.55	10.79	16.70	3.35	2.48	1.97	1.07	1.58	0.12	2.76	M6	10.1	RAC-206
38.01	12.76	20.64	3.35	2.48	1.97	1.07	1.58	0.12	2.76	M6	11.2	RAC-208
47.53	14.73	24.58	3.35	2.48	1.97	1.07	1.58	0.12	2.76	M6	12.3	RAC-2010
13.49	7.13	9.10	3.94	2.95	2.36	1.31	1.58	0.12	3.15	M6	9.9	RAC-302
26.99	9.09	13.04	3.94	2.95	2.36	1.31	1.58	0.12	3.15	M6	11.5	RAC-304
40.48	11.06	16.98	3.94	2.95	2.36	1.31	1.58	0.12	3.15	M6	13.0	RAC-306
53.91	13.04	20.91	3.94	2.95	2.36	1.31	1.58	0.12	3.15	M6	14.5	RAC-308
67.40	15.01	24.85	3.94	2.95	2.36	1.31	1.58	0.12	3.15	M6	16.1	RAC-3010
21.65	7.32	9.90	5.12	3.74	3.15	1.19	1.97	0.12	4.33	M6	18.7	RAC-502
43.30	9.29	13.24	5.12	3.74	3.15	1.19	1.97	0.12	4.33	M6	21.6	RAC-504
64.95	11.26	17.17	5.12	3.74	3.15	1.19	1.97	0.12	4.33	M6	24.5	RAC-506
86.49	13.24	21.11	5.12	3.74	3.15	1.19	1.97	0.12	4.33	M6	27.3	RAC-508
108.14	15.21	25.05	5.12	3.74	3.15	1.19	1.97	0.12	4.33	M6	30.2	RAC-5010
43.71	8.71	10.68	7.09	5.32	4.33	1.82	3.70	0.12	5.91	M10	38.1	RAC-1002
87.43	10.67	14.61	7.09	5.32	4.33	1.82	3.70	0.12	5.91	M10	43.2	RAC-1004
131.14	12.64	18.55	7.09	5.32	4.33	1.82	3.70	0.12	5.91	M10	48.3	RAC-1006
174.64	14.61	22.49	7.09	5.32	4.33	1.82	3.70	0.12	5.91	M10	53.4	RAC-1008
218.35	16.58	26.43	7.09	5.32	4.33	1.82	3.70	0.12	5.91	M10	58.4	RAC-10010
69.30	9.56	11.53	9.06	6.69	5.51	2.02	4.45	0.12	7.87	M10	55.8	RAC-1502
138.61	11.53	15.47	9.06	6.69	5.51	2.02	4.45	0.12	7.87	M10	64.6	RAC-1504
207.91	13.49	19.41	9.06	6.69	5.51	2.02	4.45	0.12	7.87	M10	73.4	RAC-1506
276.87	15.47	23.34	9.06	6.69	5.51	2.02	4.45	0.12	7.87	M10	82.2	RAC-1508
346.17	17.44	27.28	9.06	6.69	5.51	2.02	4.45	0.12	7.87	M10	91.1	RAC-15010