

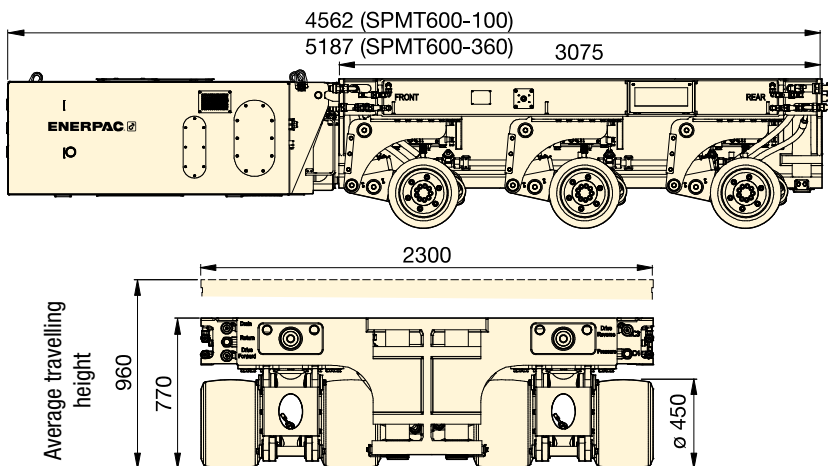

SPMT, Self-Propelled Modular Transporter

▼ SPMT600-360 with MTPP-360 hydraulic power unit (HPU)



- Modular design for multiple configurations.
- Minimized height and slim design are ideal for in-plant operation
- Intelli-Drive wireless control system is intuitive and easy to use
- One power pack can operate 2-3 trailers maximum depending on model
- Two trailers and power pack can be shipped inside a 20 ft. container
- Hydraulic power unit is tier-4 diesel engine for reduced emissions.



Capacity (per trailer)	Model Number	Maximum Configuration	Steering Range	Lifting Stroke	 HPU *	 Trailer
ton (kN)		(trailer in rows)	(degrees)	(mm)	(kg)	(kg)
60 (600)	SPMT600-100	4 x 2	-50° - +50°	384	2500	8000
	SPMT600-360	6 x 2	-179° - +179°	384	2800	8300

* HPU = 54 kW Power Pack Diesel is sold separately.

SPMT Series

Capacity:

60 ton (600 kN)

Transport Speed (unloaded - loaded):

3 - 1,5 km/h

Motor Size:

54 kW



Self-Propelled Modular Transporter

The Enerpac Self-Propelled Modular Transporter (SPMT) features a minimized height and slim design, which makes it very easy to operate in confined spaces. Each wheel unit has a steering function as well as a lifting cylinder at its disposal. Two axles are driven, the centre axle is non-driven. Wheel propulsion is established by wheel drives.

The SPMT is operated by the Intelli-Drive Remote Controller. This remote controller can be used both hard wired and wireless (based on radio frequency).

The SPMT is a modular system and can be built up to a maximum configuration of six transporters in a row and two in the width. This is the maximum setup of units that can work together on just one Intelli-Drive Remote Controller.

The SPMT is a modular system comprised of trailers with 3 axle lines each and diesel hydraulic power units (HPU). Depending on the model number, the trailers and HPUs can be configured to a maximum of 4 trailers in 2 rows (4x2) or 6 trailers in 2 rows (6x2).

▼ Turbine rotor transport.

